

DYNAMATIC TECHNOLOGIES LIMITED

C O R P O R A T E P R E S E N T A T I O N



CONFIDENTIAL INFORMATION



This presentation contains confidential information regarding Dynamatic Technologies Ltd and its subsidiaries (hereinafter referred to as “Dynamatic” or the “Company”). By accepting this presentation, the recipient enters into the following obligations:

The recipient agrees that it will cause its directors, officers, employees, representatives and advisers to use the information provided in this presentation only to evaluate a specific transaction concerning Dynamatic and its business and for no other purpose.

The Recipient will not divulge any information to any other party without the prior written consent of the Company. Upon the Company’s consent, the recipient shall enter into a confidentiality undertaking with any third party, in particular advisers, that such information is passed on to. Irrespective of the confidentiality undertaking given herein, all other confidentiality undertakings or agreements entered into by the recipient shall remain in full force and effect.

DISCLAIMER

The information contained in this presentation was obtained from the Company and its sources. Any estimates and projections contained herein have been prepared by the management of the Company and involve significant elements of subjective judgement and analysis, which may or may not be correct.

This presentation is confidential, copyright and/or privileged. If you are not the intended recipient, please telephone or email the sender and delete this message. All communication, inquiries and requests pertaining to this presentation and a potential transaction should be directed to:

Mr. Chalapathi P

Chief Financial Officer

F: +91 80 2839 5823

E: chalapathi.p@dynamatics.net

INDEX



1. Group Overview	4
2. Business Divisions	
Hydraulics	
• Business Snapshot	13
• Hydraulics, India	14
• Hydraulics, UK	23
Automotive & Metallurgy	
• Business Snapshot	30
• Automotive & Metallurgy, India	31
• Automotive & Metallurgy, Germany	38
Aerospace & Defence	
• Business Snapshot	45
• Aerospace & Defence, India	46
• Aerospace & Defence, UK	62
3. Financial Overview	68



GROUP OVERVIEW

MANUFACTURER OF HIGHLY ENGINEERED PRODUCTS



Hydraulics



**Aerospace &
Defence**



**Automotive &
Metallurgy**

GROUP OVERVIEW



Founded	<ul style="list-style-type: none">7th March 1973
Registered & Corporate Office Address	<ul style="list-style-type: none">Dynamatic Park, Peenya, Bangalore – 560 058, IndiaURL : www.dynamatics.comTel : +91 80 2839 4933 / 34 / 35Fax : +91 80 2839 5823CIN : L72200KA1973PLC002308
Business Segments & Blue Chip Customers	<ul style="list-style-type: none">Automotive: Volkswagen Group (Germany), BMW (Austria), Borg Warner Turbo Emission Systems (Germany), MAN (Germany), Hyundai Motors (India), Daimler (India), Chassis Brakes International, Haldex (India), Turbo Energy, TVS Sundaram Fasteners, Isuzu Motors (India), Myunghwa (India)Hydraulics: Mahindra & Mahindra, TMTL, AGCO, Escorts, CNH, Wirtgen, Atlas, COCPCO, TAFE, Vst, HAL, Same Deutz Fahr, HVF, Cummins, ACE, MTPF, DLW, John Deere, JCB, Terex, Mexico Alexander Dennis (UK), MacDonAerospace and Defence: Airbus, Bell, Boeing, HAL, Bharat Electronics Limited, Dassault Aviation, GKN Aerospace, Leonardo Aerospace, Lockheed Martin, Spirit Aerosystems
Locations	<ul style="list-style-type: none">India: 6 Industrial Complexes & 2 Engineering CentersEurope: 3 Industrial Complexes & 1 Engineering Center
Listed on	<ul style="list-style-type: none">NSE & BSE
Group Revenue	<ul style="list-style-type: none">FY'20 - INR 13,212 Million
Group EBITDA	<ul style="list-style-type: none">FY'20 - INR 1,376 Million
Employees	<ul style="list-style-type: none">FY'20 - Over 2754
Patents Held	<ul style="list-style-type: none">16 (3 awaiting registration)

INR 1 Million = INR 1,000,000

BUSINESS STRUCTURE



DYNAMATIC TECHNOLOGIES LIMITED INDIA

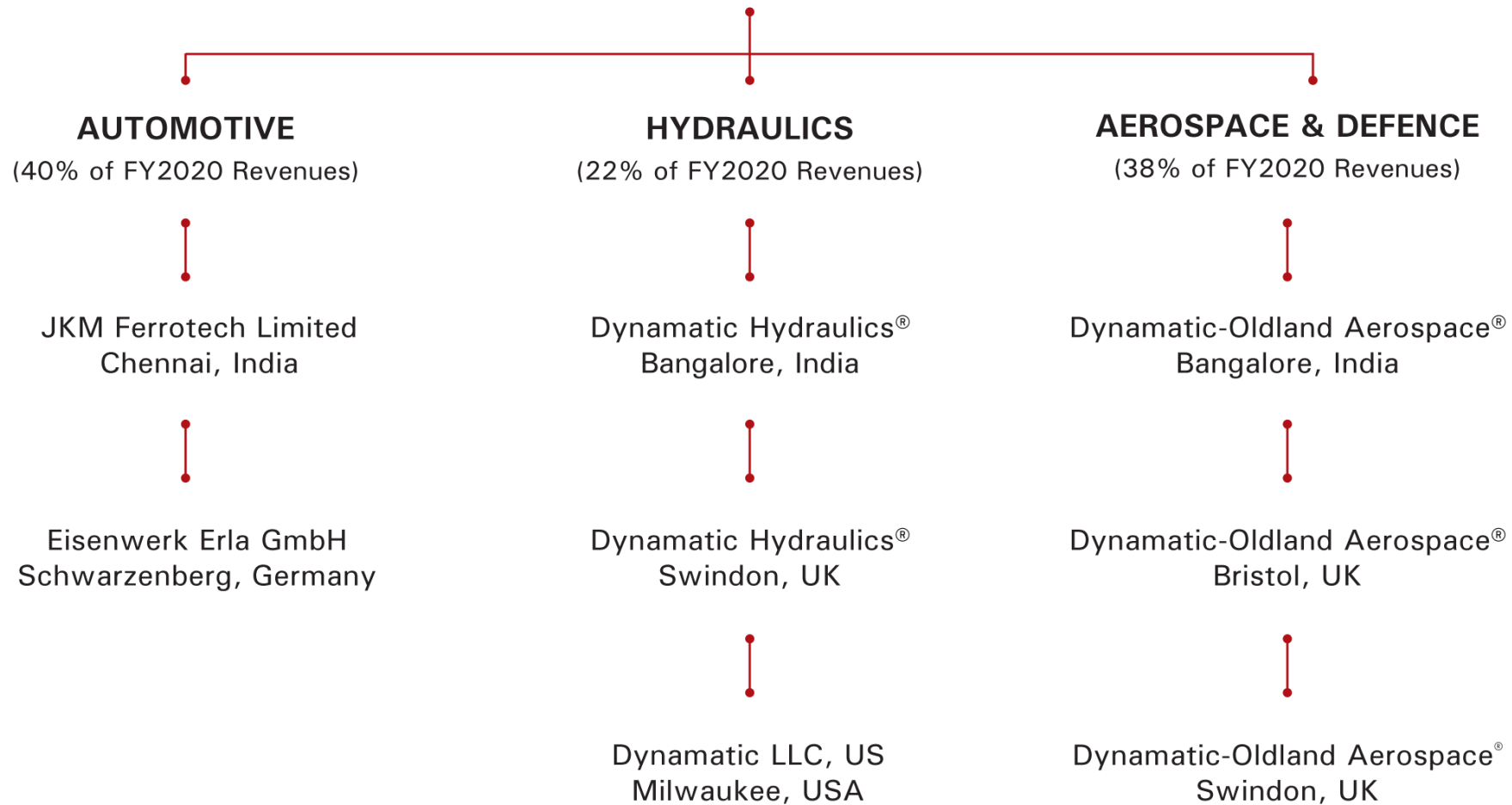

GLOBAL PRESENCE

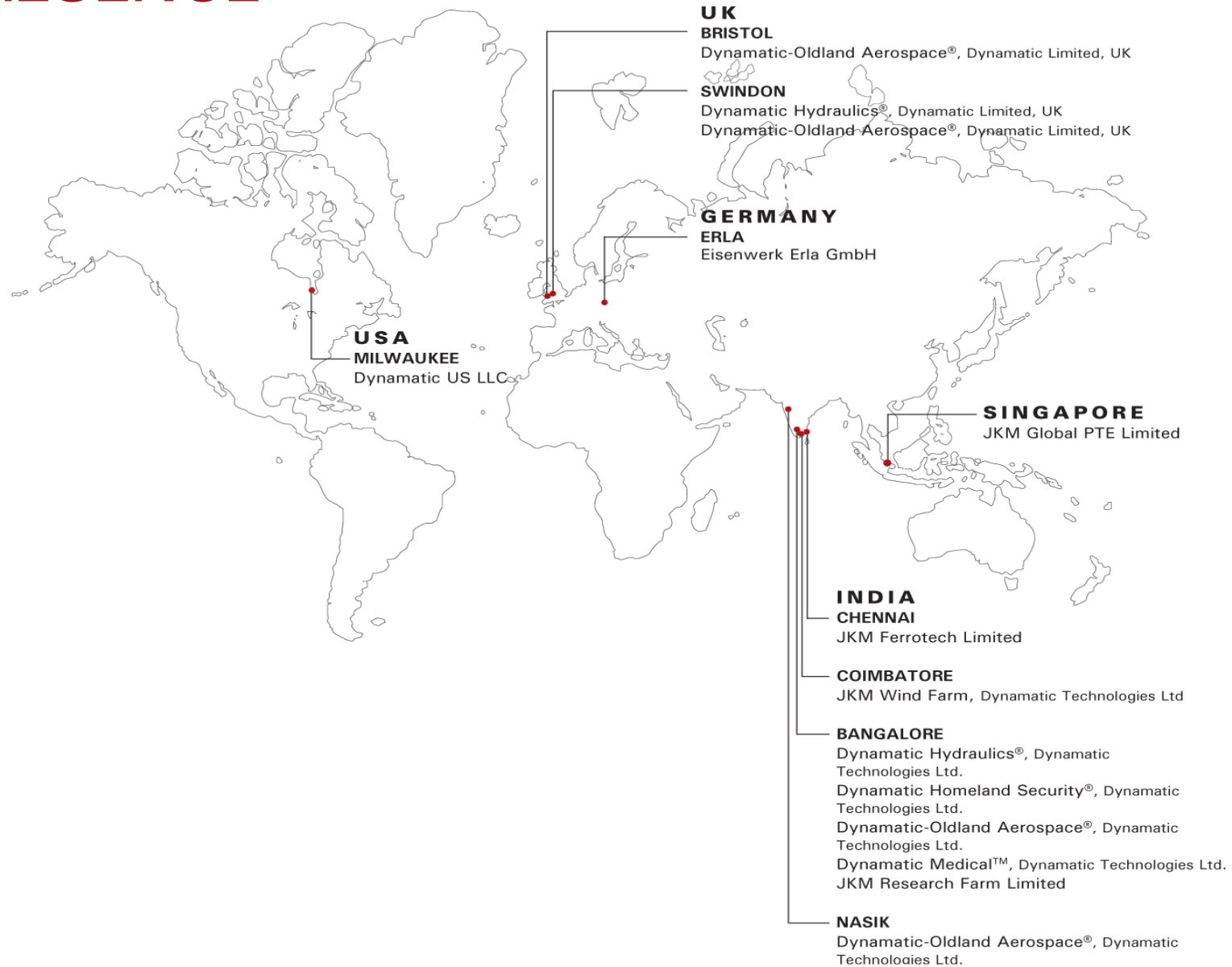

VERTICALLY INTEGRATED MANUFACTURING STRUCTURE

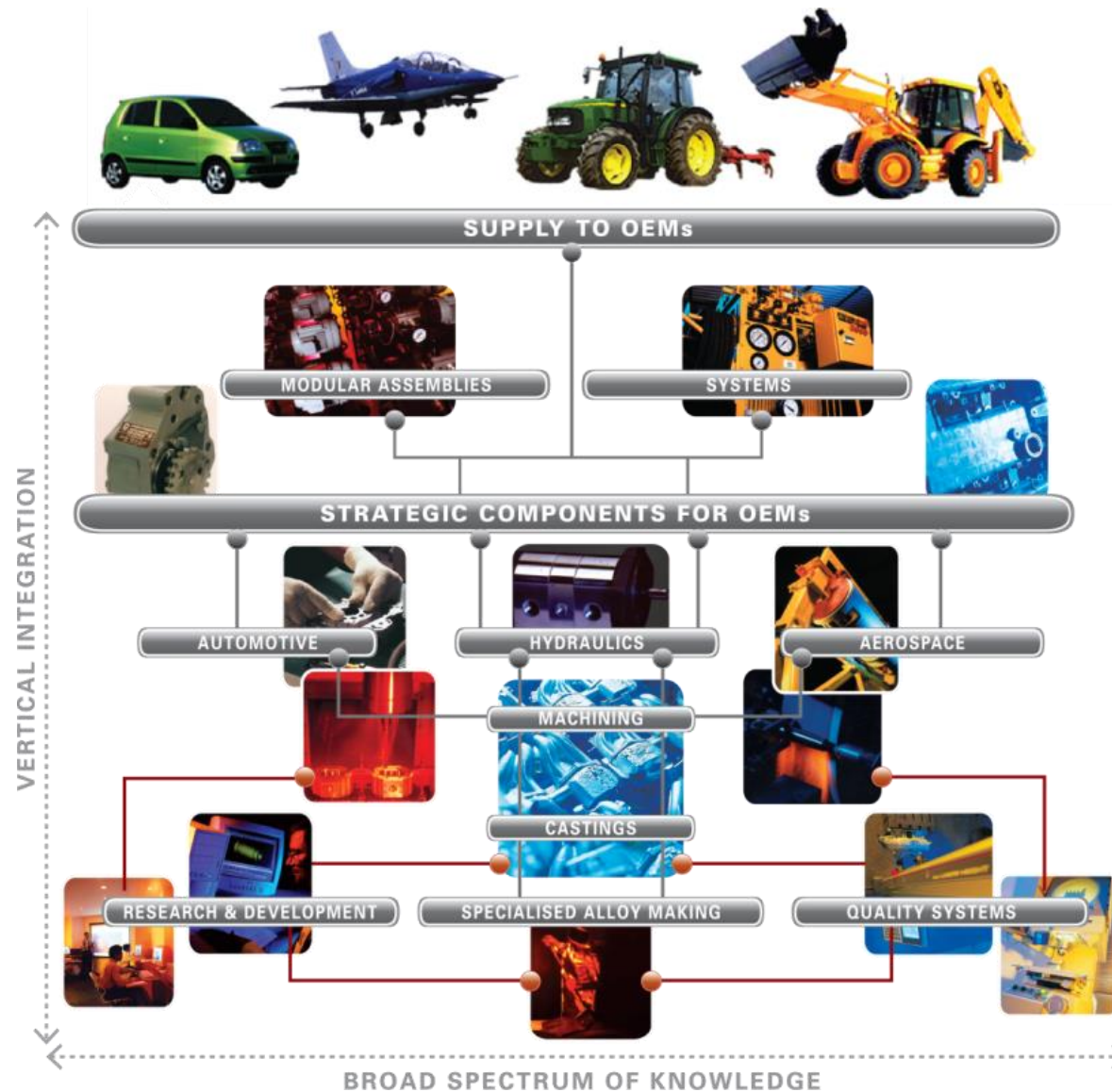

CORPORATE STRUCTURE

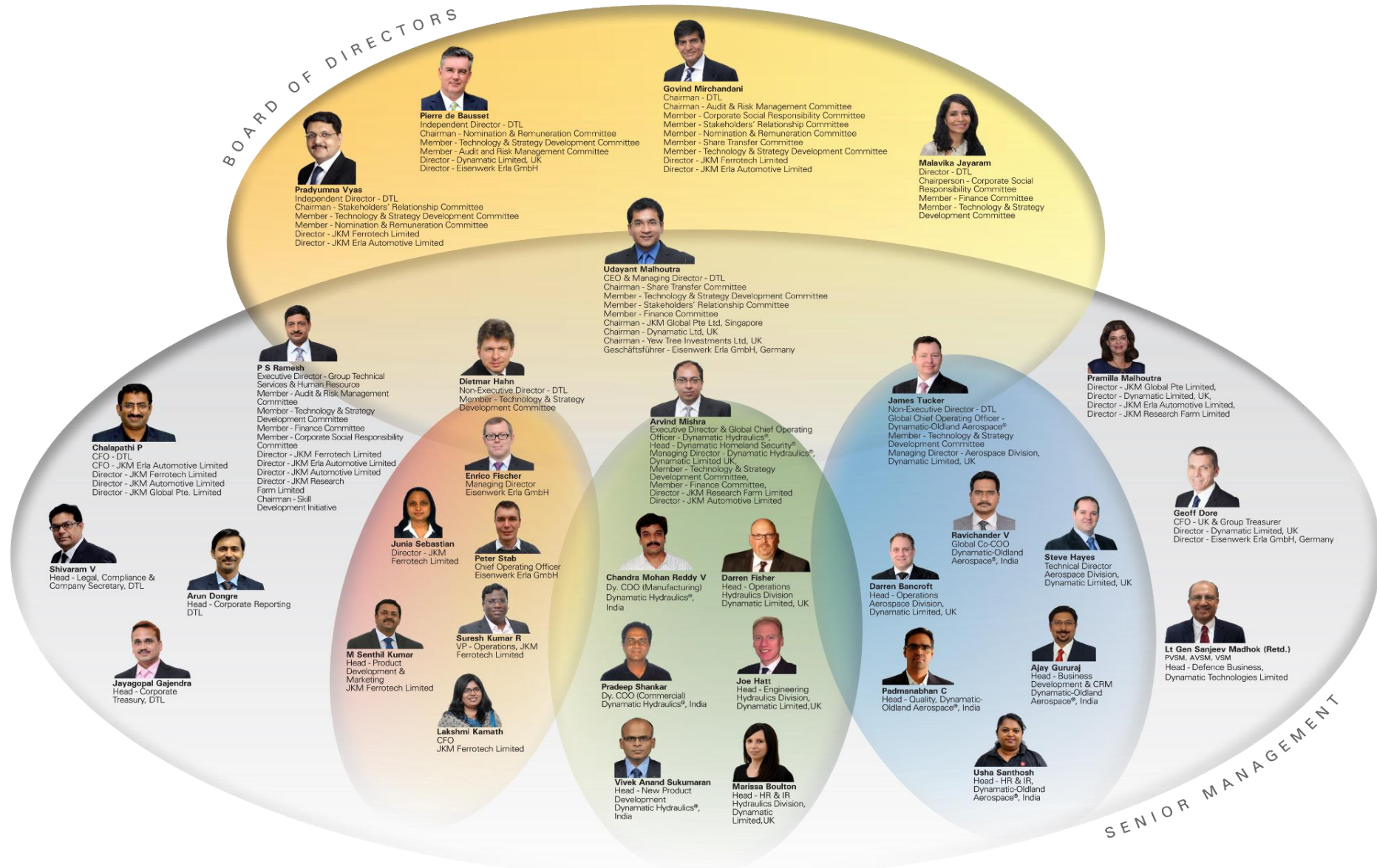

PARTNERS



Auditors

M/s. Deloitte Haskins & Sells LLP
Chartered Accountants, Bangalore

Internal Auditors

M/s. KPMG Assurance and Consulting
Bangalore

Credit Rating

India Ratings & Research Pvt Ltd

Business Scope Report

Dun & Bradstreet

Lead Bankers

- Axis Bank Limited
- Bank of India
- Commerz Bank
- Deutsche Leasing
- DMG Mori Finance
- Export-Import Bank of India
- ICICI Bank Limited
- IndusInd Bank Limited
- Kotak Mahindra Bank Limited
- LBBW
- Royal Bank of Scotland
- Siemens Financial Services
- TARGO Leasing



BUSINESS DIVISIONS
HYDRAULICS

BUSINESS SNAPSHOT



Brand Names	<ul style="list-style-type: none">• Dynamatic Hydraulics®
Locations	<ul style="list-style-type: none">• Bangalore, India and Swindon, UK
Key Customers	<ul style="list-style-type: none">• Mahindra & Mahindra, TMTL, AGCO, Escorts, CNH, Wirtgen, Atlas, COCPCO, TAFE, Vst, HAL, Same Deutz Fahr, HVF, Cummins, ACE, MTPF, DLW, John Deere, JCB, Terex, Mexico Alexander Dennis (UK), MacDon
Revenue	<ul style="list-style-type: none">• FY'20 - INR 2,950 Million
EBITDA	<ul style="list-style-type: none">• FY'20 - INR 149 Million
Competitive Market Position	<ul style="list-style-type: none">• One of the world's top producers of hydraulic gear pumps• Leadership in Hydraulic Gear Pumps market for 45 years• Design & Development partnerships with major global Tractor OEMS
R&D	<ul style="list-style-type: none">• Owns design IP of all products• Largest number of product variants in the world

HYDRAULICS, INDIA



- Dominant Player in the Indian Market - 65% share of the India organized tractor market
- Global Reach: Supplier of choice to leading Tractor OEMS including John Deere, CNH, Claas, Agco & Same Deutz-Fahr
- Comprehensive Range of Gear Pumps for all applications
- Growth Drivers: Agriculture, Infrastructure & Energy sectors
- Technology Leadership - Among the World's finest Engineering Laboratories
- High Quality

HYDRAULICS JOURNEY

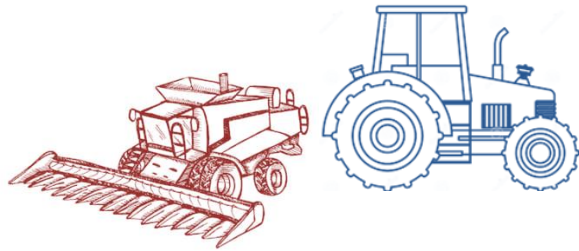

**Farm
Mechanization**

1974



JOHN DEERE

**Global
Partnership**

1990's



**Global
Market**

2007



**Milwaukee, US
Started**

2016

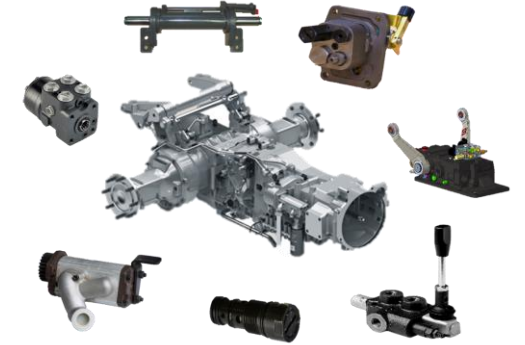

**Tractor Hydraulics
Wallet Share**

2019-20

Design, Develop, Manufacture Gear Pumps

Partnered with Global OEMs for Bespoke Pump Design & Development

Global Footprint - Acquired Sauer Danfoss, UK

HYDRAULICS, INDIA

Facilities

Location : Bangalore, India



Dynamatic Hydraulics®, Unit I



Dynamatic Hydraulics®, Unit II



Dynamatic Hydraulics®, Unit III

- 3 Manufacturing Units in Peenya Industrial Area, Bangalore

HYDRAULICS, INDIA

R&D / Engineering

- Comprehensive R&D Capabilities
- Advanced Endurance & Performance
- Testing Facilities including SCADA
- Digital Design, Rapid Prototyping
- Engineering Laboratory certified as 'Recognized In-House R&D Unit' by Dept. of Scientific & Industrial Research (DSIR), Government of India



TRACTOR HYDRAULICS, COMPLETE SOLUTIONS

Product Offerings



**Power Steering
Valves**



**Power Steering
Cylinder**



Pumps



**Pressure &
Flow Control**



**Hitch Control
Valve**



Electronic LH Assy

HYDRAULICS, INDIA

Product Offerings



Aluminum Body Pumps

For Agricultural Equipment
& Industrial Applications



Cast Iron Gear Pumps

For Construction Equipment
& Earth Moving Equipment



HYDRAULICS, INDIA

Product Offerings



Cummins Lube Oil Pump



Quadruple Pump

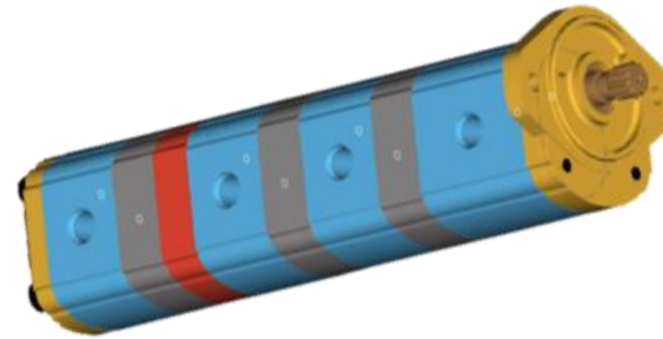

Tractor Hitch Control Valves

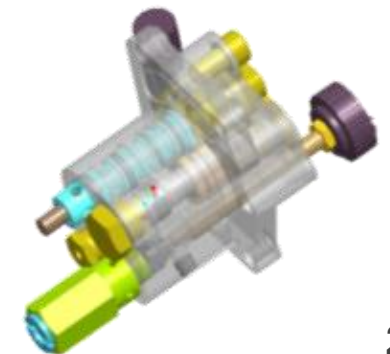
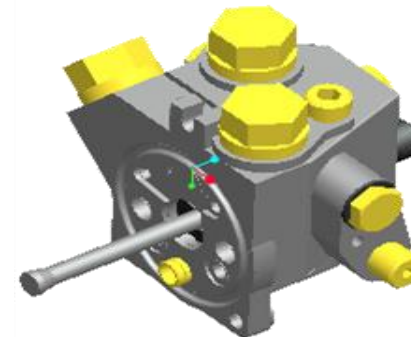
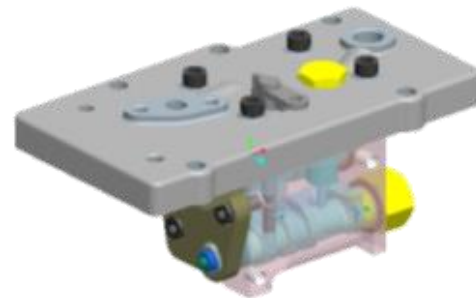
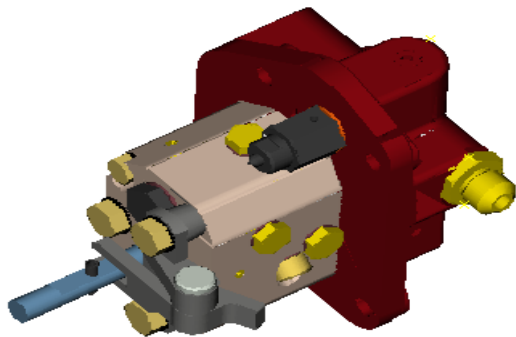

HYDRAULICS, INDIA

Product Offerings



Rockshaft Assembly

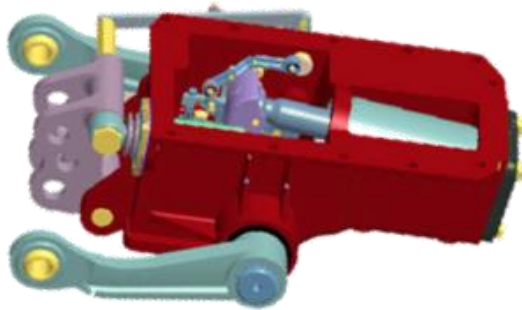

Built To Print Tractor Control Valves



Various Applications



Lube Oil Pump
Marine Applications



Gear Motor



Internal Gear Pump



Medium Pressure Pump

HYDRAULICS, INDIA

Quality Accreditations



- ISO9001:2015 QMS Certification by DQS
- ISO14001:2015 EMS Certification by DQS
- ISO45001:2018 OH&S Certification by DQS

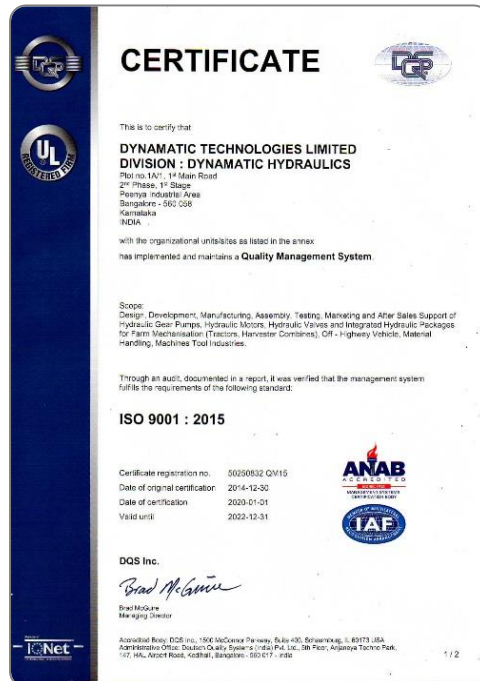

ISO 9001

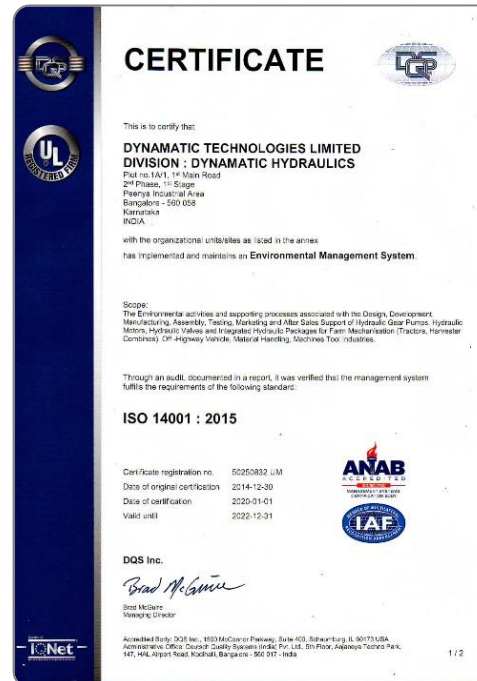

ISO 14001

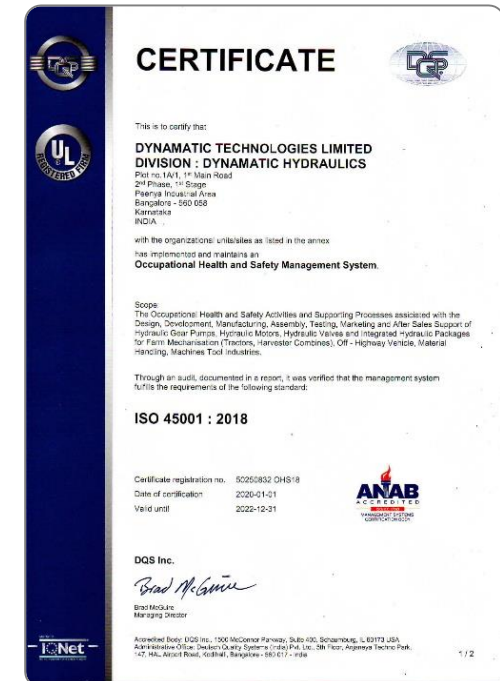

ISO 45001

HYDRAULICS, UK



- Six decades of engineering and manufacturing excellence.
- Acquired by Dynamatic Technologies in 2007
- Products include performance engineered hydraulics products such as aluminium and cast Iron gear pumps, fan drive system, engineered packages, etc
- Supplier of choice to leading Global Tractor OEMS including John Deere and Case New Holland
- Technology Leadership - Among the World's finest Hydraulic Design Laboratories
- High Quality and Lean Focus



HYDRAULICS, UK

Facilities

Location : Swindon, UK



Dynamatic Hydraulics®
Dynamatic Limited, UK



HYDRAULICS, UK

R&D / Engineering



- Possesses Advanced design knowledge for Mobile Hydraulics Sector
- Comprehensive Product Testing and validation capabilities

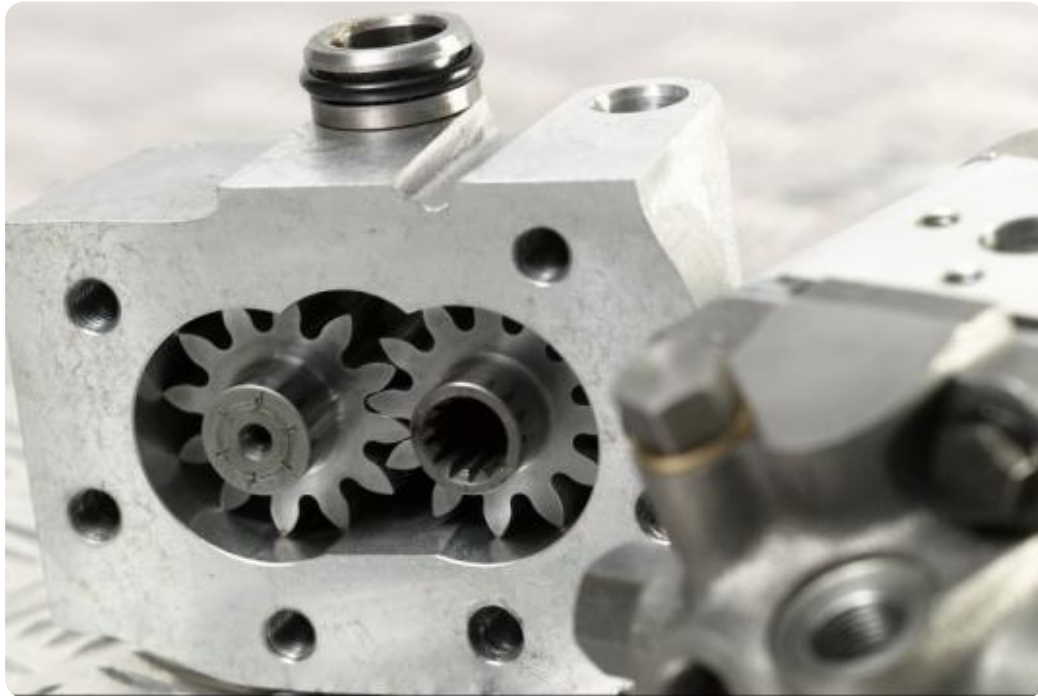

HYDRAULICS, UK

Product Offerings



Aluminum Body Hydraulic Gear Pumps and Integrated Gear/Piston Pump Packages



Cast Iron Gear Pumps



HYDRAULICS, UK

Product Offerings



Fan Drive Motor, Integrated Control Valve and Tandem Gear Pump



Engineered Packages

High Value-add Products combining Multiple Pump & Valve Elements in a compact unit



HYDRAULICS, UK

Quality Accreditations

- Accredited to the British Standards Institute Quality Management System, ISO 9001 2008
- Approved as Partner by John Deere
- Approved supplier to ADL, Terex Limited & ZF
- Member of the BFPA



ISO 9001:2015



BUSINESS DIVISIONS
AUTOMOTIVE & METALLURGY

BUSINESS SNAPSHOT



Brand Names	<ul style="list-style-type: none">• Eisenwerk Erla GmbH• JKM Ferrotech Limited
Locations	<ul style="list-style-type: none">• Chennai, India and Schwarzenberg, Germany
Key Customers	<ul style="list-style-type: none">• Volkswagen Group (Germany), BMW (Austria), Borg Warner Turbo Emission Systems (Germany), MAN (Germany), Hyundai Motors (India), Daimler (India), Chassis Brakes International, Haldex (India), Turbo Energy, TVS Sundaram Fasteners, Isuzu Motors (India), Myunghwa (India)
Revenue	<ul style="list-style-type: none">• FY'20 - INR 5,261 Million
EBITDA	<ul style="list-style-type: none">• FY'20 - INR 137 Million
Competitive Market Position	<ul style="list-style-type: none">• Produces highly engineered automotive components for highway, off-highway and technology oriented applications• One of the world's largest manufacturers of automotive turbochargers• Single source supplier to global OEMS for selected products

AUTOMOTIVE & METALLURGY, INDIA



- Producer of high quality Ferrous components for Automotive applications
- **Single Source** to Global Auto OEMs for critical engine & transmission components - catering to over 50% of Indian Passenger Car Market
- Strategically Located in Chennai, one of India's leading Automotive Hubs

AUTOMOTIVE & METALLURGY, INDIA

Facilities

- Manufactures high precision, complex metallurgical ferrous castings for automobile engines and turbochargers
- Compliant with ISO 9001 and TS16949 standards and approved by BMW, Hyundai and Toyota
- Capacity: 26,000 MTPA



JKM Ferrotech Limited

Location : Chennai, India



AUTOMOTIVE & METALLURGY, INDIA

R&D/Engineering



Magma Casting Simulation

- Development of thin wall castings
- Capable of executing Aluminum Gravity Die Cast parts with intricate contours.
- Complex core assembly
- “Cast in” oil ways and galleries
- Competence in alloying metals and complex castings.

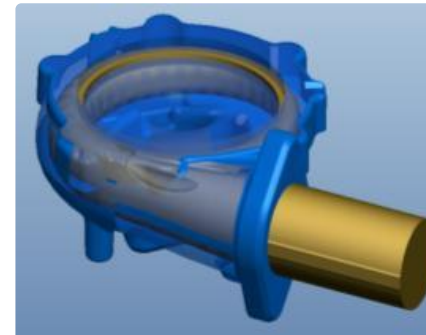
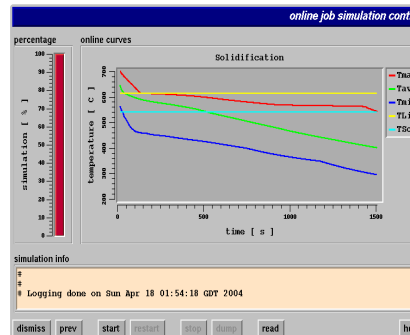
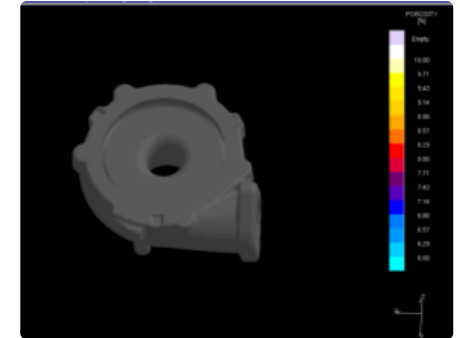
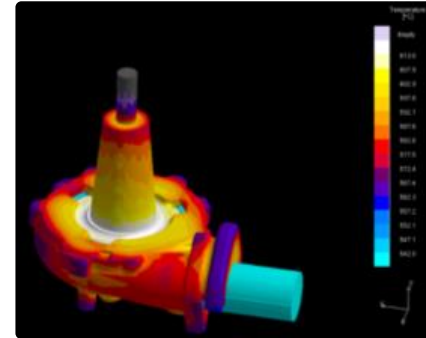
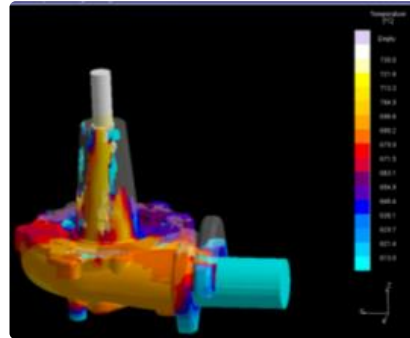

AUTOMOTIVE & METALLURGY, INDIA

Product Offerings



Engine & Transmission Parts



Exhaust Manifold Assy.

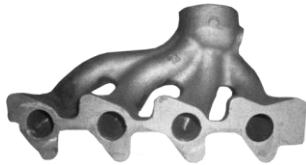

Air Tube assembly



Water Pump

Oil Pump



Fork Shift



Rocker Arm (A&B)



Chassis Parts

AUTOMOTIVE & METALLURGY, INDIA

Product Offerings



Flywheel (VW)



Brake Caliper (Mando)



Lanchester Housing (Daimler)

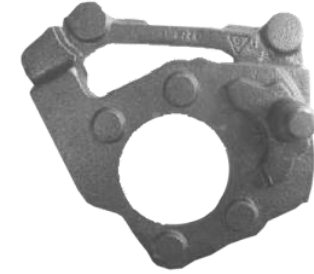

Brake Mounting Plate



Bracket



Turbocharger Center bearing housing



End Yoke



Compressor Mounting Bracket

AUTOMOTIVE & METALLURGY, INDIA

Product Offerings



**Compressor Housing
(Honeywell)**



**Compressor Housing
(Honeywell)**



**Fork shift
(Getrag Ford)**



**Inlet Manifold
(Hyundai)**

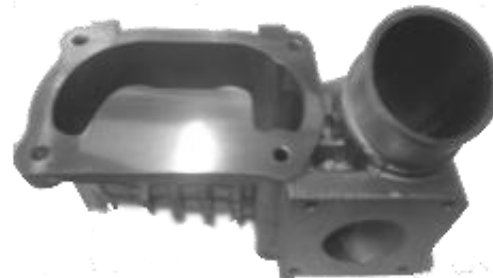

**Air tube inlet
(Renault Nissan)**



**Fork shift
(Getrag Ford)**

AUTOMOTIVE & METALLURGY, INDIA

Quality Accreditations

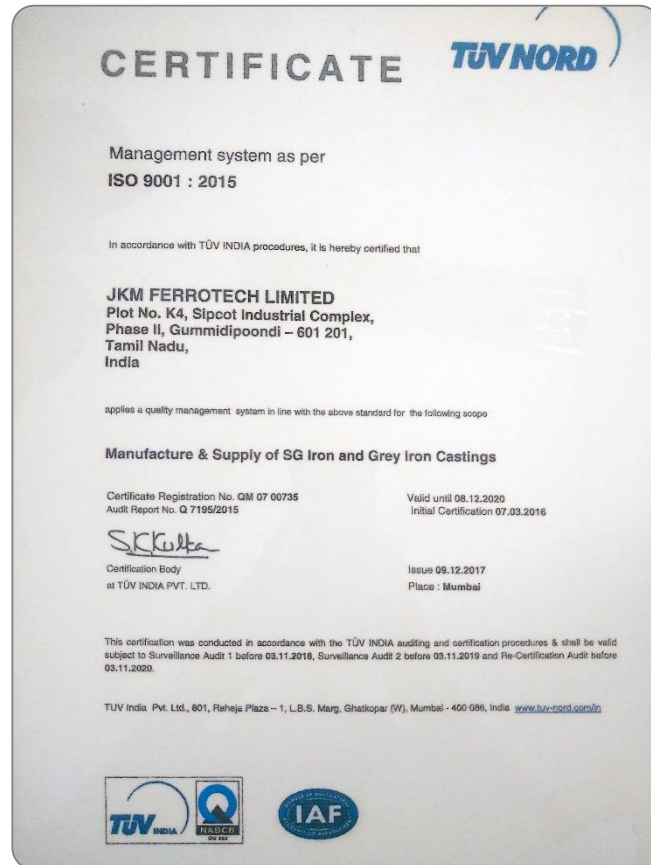

ISO 9001:2015



IATF 16949:2016

AUTOMOTIVE & METALLURGY, GERMANY

Eisenwerk Erla GmbH



- 600 year old history of iron extraction and processing; One of the finest ferrous foundries in Europe
- Manufacturer of ferrous and special alloy castings. Products include Turbine housings, Exhaust Manifolds, Crankshaft Bearing Caps & other Automotive Castings
- Specialisation in high-grade alloys such as SiMo, Ni-Resist, Heat Resistant Steel and Core Making Technology of Turbocharger castings
- Over 12.5% share of Global Petrol Turbocharger market



AUTOMOTIVE & METALLURGY, GERMANY

Facilities



Eisenwerk Erla GmbH



Location : Schwarzenberg, Germany

ADVANCED ROBOTIC MANUFACTURING



IN GERMANY

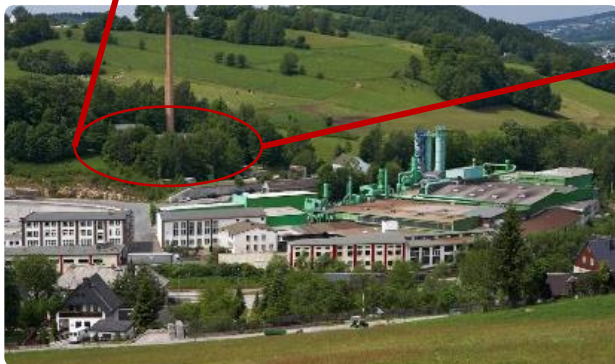
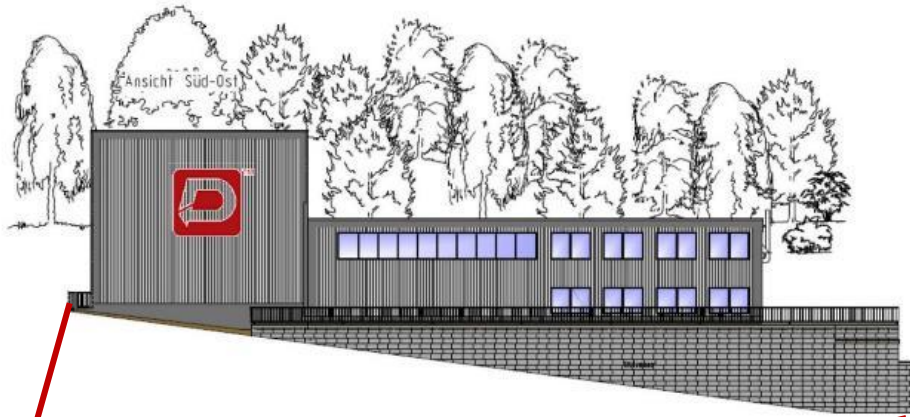

AUTOMOTIVE & METALLURGY, GERMANY

Product Offerings



Turbine Housings



Crankshaft Bearing Cap



For Use In Turbo Charged Engines



AUTOMOTIVE & METALLURGY, GERMANY

Quality, Environmental & Energy Accreditations



ISO-TS 16949:2009



DIN EN ISO 14001:2004



ISO 50001-2011

AUTOMOTIVE & METALLURGY, GERMANY

Research & Development



- Strong R&D capabilities and Patented Technologies specific to the Automotive Industry
- Collaboration with major German technical institutes – Technical University of Freiberg, West Saxon University of Applied Sciences of Zwickau Germany and InnCoa





BUSINESS DIVISIONS
AEROSPACE & DEFENCE

BUSINESS SNAPSHOT



Brand Names	<ul style="list-style-type: none">• Dynamatic-Oldland Aerospace®
Locations	<ul style="list-style-type: none">• Bangalore & Nasik - India, Bristol & Swindon - UK
Key Customers	<ul style="list-style-type: none">• Airbus, Bell, Boeing, HAL, Bharat Electronics Limited, Dassault Aviation, GKN Aerospace, Leonardo Aerospace, Lockheed Martin, Spirit Aerosystems
Revenue	<ul style="list-style-type: none">• FY'20 - INR 4,976 Million
EBITDA	<ul style="list-style-type: none">• FY'20 – INR 1232 Million
Competitive Market Position	<ul style="list-style-type: none">• Demonstrated leader for the development of exacting Air Frame Structures and Precision Aerospace Components• Tier I supplier to Airbus, Boeing and Bell Helicopter• Delivers high value to customers by combining technical competence of the UK facilities with the cost and manufacturing advantages offered by the Indian facilities

AEROSPACE & DEFENCE, INDIA



- Pioneer and demonstrated leader in the Indian private sector for manufacture of high precision airframe structures and aerospace components
- Largest infrastructure in the Indian private sector, possesses stringent regulatory approvals and quality certifications that present significant barriers to entry
- Strong Partnerships with MoD and agencies of national importance like DRDO, HAL, NAL, Bharat Electronics Limited etc
- Only Indian Company to be a Tier One Supplier to Airbus, Boeing and Bell Helicopter
- Also provides security solutions to India's national defence forces, homeland security forces, police and civilian agencies.

AEROSPACE & DEFENCE, INDIA

Facilities



Location : Bangalore, India

AEROSPACE JOURNEY - INDIAN CUSTOMERS



In 1994, the Aerospace Division of Dynamatic commences operations as a garage start-up in Peenya, Bangalore.

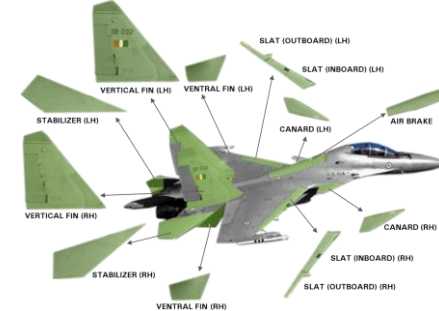
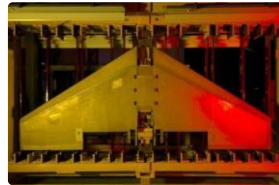
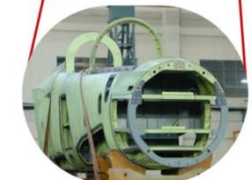

IMAGE COURTESY : HAL



1993-1994

Arjun MBT & T-72

Manufactured Hydraulic Transmission System, Steering Control System, Turret Control System & Brake Actuating System

1995-1998

Lakshya - Wing & Fuselage

Aerospace Division was inducted by ADE-DRDO as a developmental partner for the rear fuselage of the Lakshya Pilotless Target Aircraft (PTA) programme

1999-2000

Intermediate Jet Trainer

Design & Development of Aileron & Flaps as a partner for the Intermediate Jet Trainer HJT-36 programme for HAL

2004 onwards

Sukhoi-30 MKI Fighter Jet

Major Control Surfaces assemblies manufactured at Dynamatic, Nashik. First Private Sector Company to be within Defence PSU (HAL). Supplied more than 100 sets to HAL

2015 onwards

Tejas – Light Combat Aircraft

Design & Build of Major Assembly Jigs, Detail Components and Assembly of Main Fuselage

AEROSPACE JOURNEY - GLOBAL CUSTOMERS



In From Tier 3 to Global Tier 1 Supplier to major OEMs like Airbus, Boeing & Bell



2007-2008

Airbus A320 Family

Dynamatic signs contract with Spirit AeroSystems (Europe) for manufacture of Flap-Track-Beams for Airbus A320 Family

2009

Boeing P-8 Poseidon

Tier 1 supplier to Boeing for manufacturing of Mission & Power Cabinets

2010

Bell 407 Program

Major Structures for Cabin Assembly which includes Aft Fuselage, Lower Fuselage and the roof assembly.

2014-2015 onwards

Boeing Chinook Ch-47F Program

Tier 1 supplier to manufacture Aft Pylon & Cargo Ramp. The program was initiated at the launch of Make in India initiative from Govt. of India. Over 75 Ship sets have been delivered till date

Airbus A330 Program

Tier 1 Supplier for Airbus for manufacturing of Flap-Track-Beams - Details Parts and Assembly.

Global Single Source delivering Flap-Track-Beams for over 750 aircraft across Airbus Family

AEROSPACE & DEFENCE, INDIA

Key Customers/Projects

Hindustan Aeronautical Limited



Lakshya Pilotless Target Aircraft
Products: Wings & Rear Fuselage.



HJT 36 Intermediate Jet Trainer
Products: Ailerons & Flaps



Sukhoi 30 MKI Fighter Bomber
Products: Vertical Fins, Slats, Cannards, Stabilisers, Air Brakes, and Ventral Fins

TEJAS LIGHT COMBAT AIRCRAFT FUSELAGE



Dynamatic Technologies Limited has been chosen as the supplier for the Front Fuselage assembly from HAL - Light Combat Aircraft Division

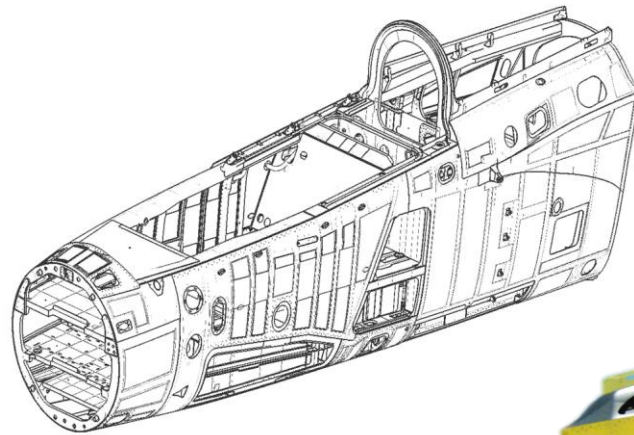
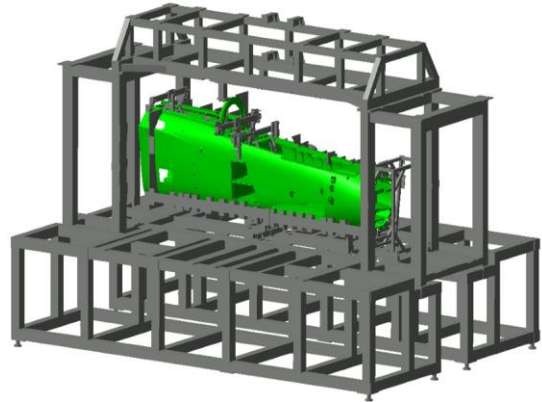
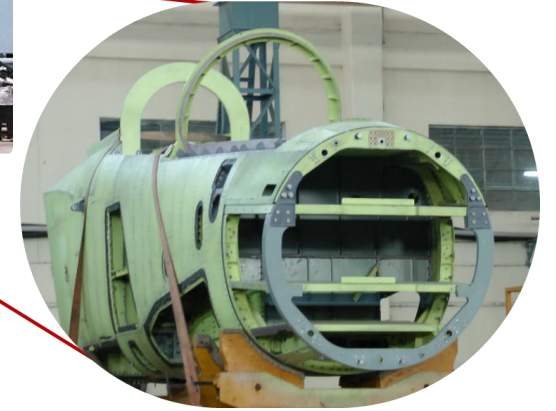

AEROSPACE & DEFENCE, INDIA

Key Customers/Projects

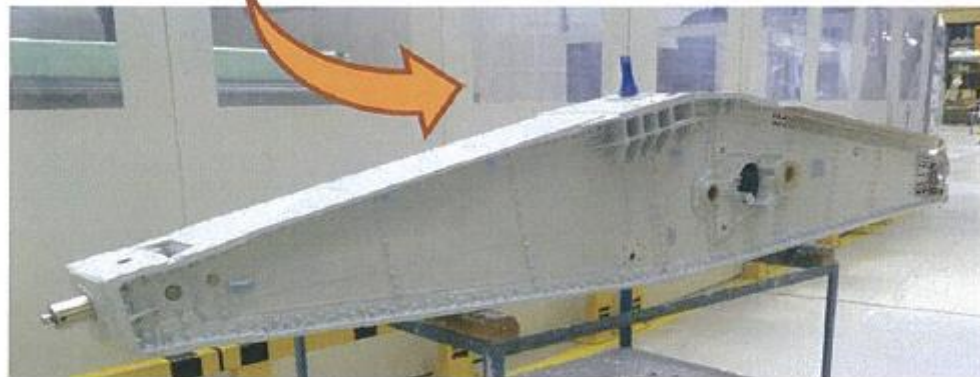
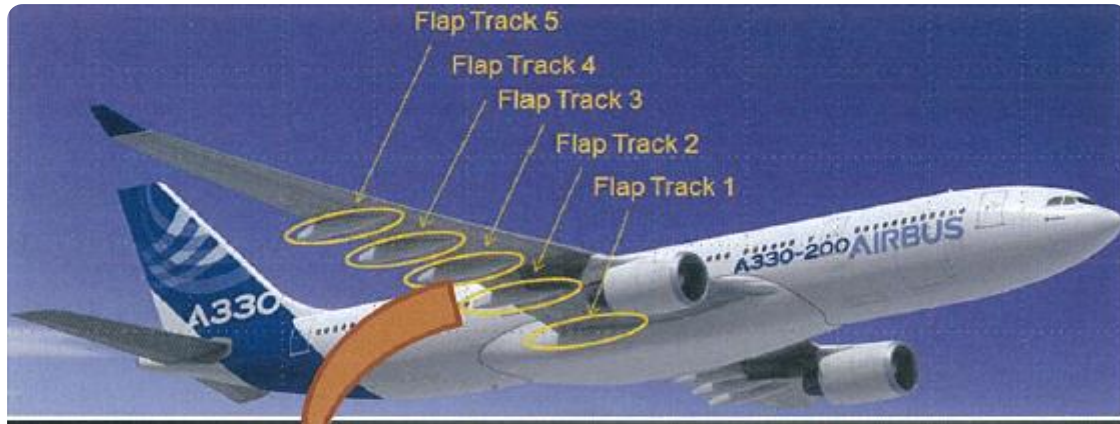

Airbus A330

Airbus A320/A321

Centre of Excellence for Airbus Flap Track Beams

Manufacturing 100% of Airbus Single Aisle

Contracted for 100 % of all Airbus Long Range

AEROSPACE & DEFENCE, INDIA

Key Customers/Projects

Boeing Chinook

Cargo Ramp Assembly Aft Pylon

Boeing P8

Mission & Power Cabinets



Pylon

Ramp



AEROSPACE & DEFENCE, INDIA



Key Customers/Projects

Major Assemblies to build Bell Helicopters 407

Item – 30 Cabin assembly

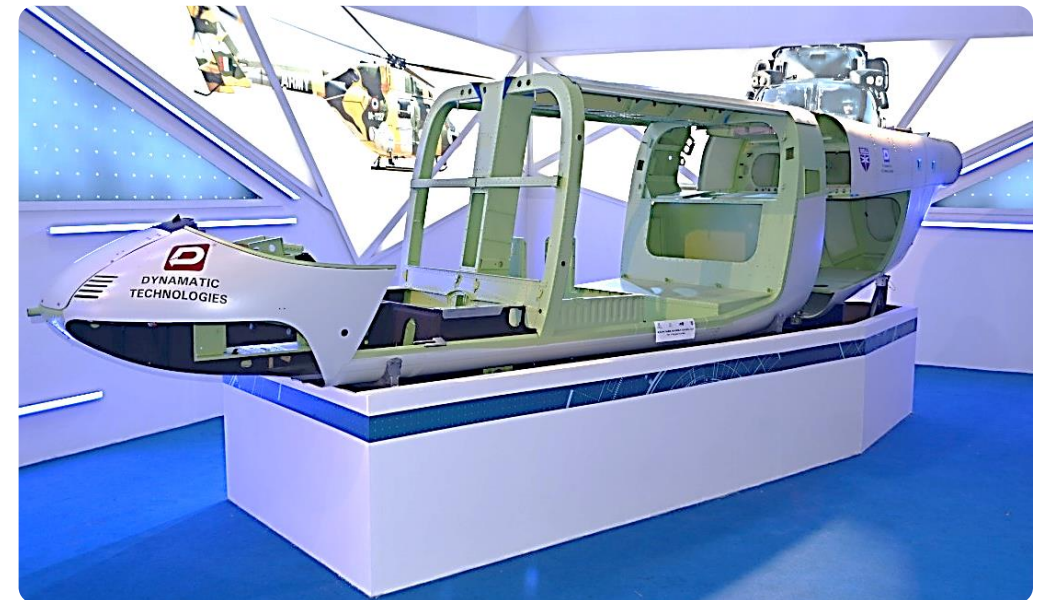
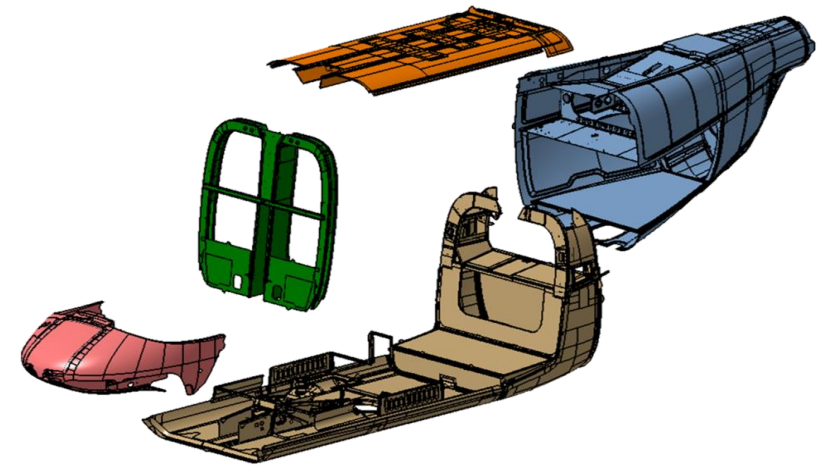
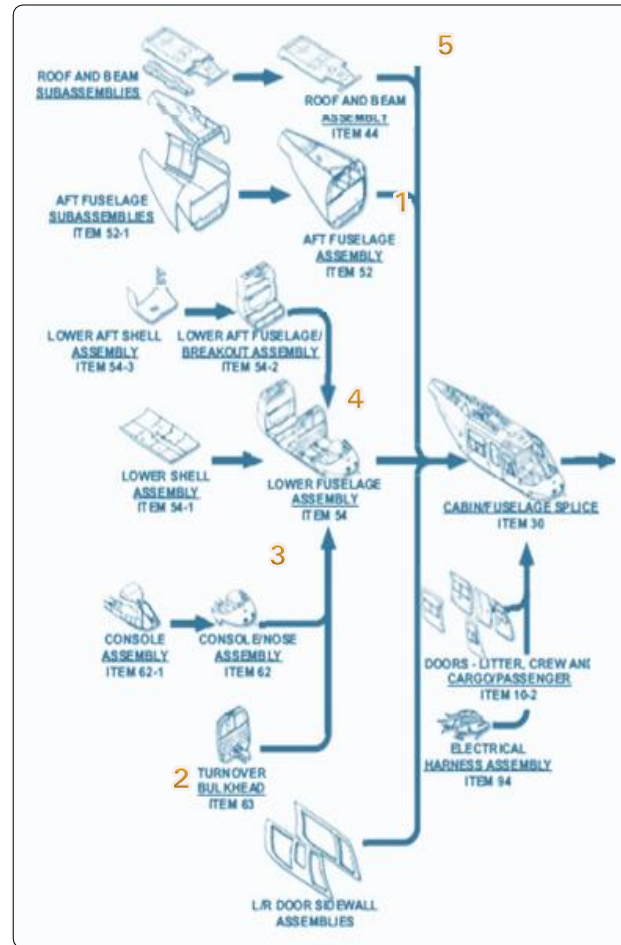
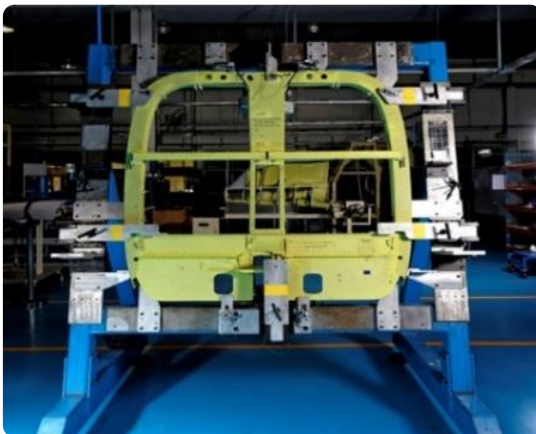

AEROSPACE & DEFENCE, INDIA

Key Customers/Projects

Assembly Tools – Dassault

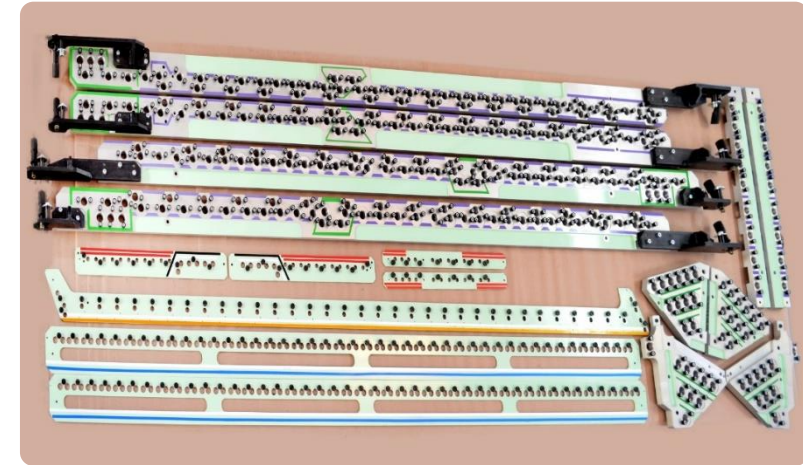

AEROSPACE & DEFENCE, INDIA

Key Customers/Projects

Assembly Tools – Dassault





AEROSPACE & DEFENCE, INDIA

Key Customers/Projects

First Tool exported from India for Boeing Space – Aug 2019



AEROSPACE & DEFENCE, INDIA

Awards & Accolades



Dr. APJ Abdul Kalam, Dr. K.G. Narayanan, Udayant Malhoutra (*LtoR*)

1999



Creative Partner Award for the year 1998-99 awarded by DRDO, ADE and ASIEO

2000



National Award for excellence in indigenisation of defence equipment by Ministry of Defence

CONSISTENTLY HAL'S BEST SUPPLIER

Awards & Accolades



2003

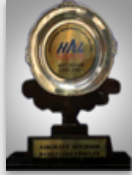

HAL Best Vendor Award for 2002-03 by HAL's aircraft division

2008



Outstanding Vendor Award for 2008 by HAL

2013



Best Supplier Award for 2013 by HAL

Delivery of 100th Shipset



2015



2016



2017



AEROSPACE & DEFENCE, INDIA

Quality Accreditations

- AS9100, DGAQA and NADCAP approved
- Quality approval from Airbus, Boeing, Bell Helicopters, HAL
- AS 9100 Rev D certified
- Entire Campus ISO 14001 and OSHAS approved
- NADCAP approval for NDT, Heat Treatment, Welding Facilities, Metrology
- ISO 27001: 2013 approval Information Security Management System
- NADCAP for Alodine process



NADCAP for Alodine



NADCAP for Heat Treatment



NADCAP for NDT



NADCAP for Welding



NADCAP for Metrology



ISO 27001



AS 9100

AEROSPACE & DEFENCE, INDIA

Homeland Security

Strategic Teaming Agreements

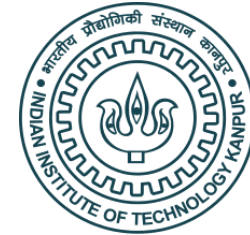

IIT - KANPUR

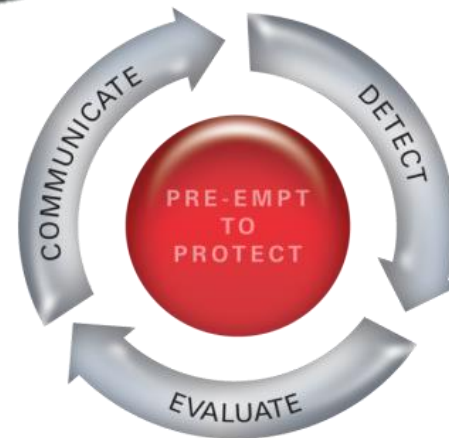

AEROSPACE & DEFENCE, UK



- High End Precision Engineering company manufacturing components and tooling for Aerospace industry
- Complex 5 axis machining capabilities for the manufacture of a vast range of machining, finishing, assembly and inspection operations to world-class standards
- Acquired by Dynamatic in 2008
- Long term contracts with OEM's & Tier1 suppliers
- Certified supplier to Airbus UK, Boeing, GKN Aerospace, Magellan Aerospace, GE Aviation Systems, Lockheed Martin, Agusta Westland, Spirit AeroSystems, UK

AEROSPACE & DEFENCE, UK

Facilities



Bristol



Swindon



Location : Bristol & Swindon UK

FULLY AUTONOMOUS ROBOTIC MANUFACTURING Facilities

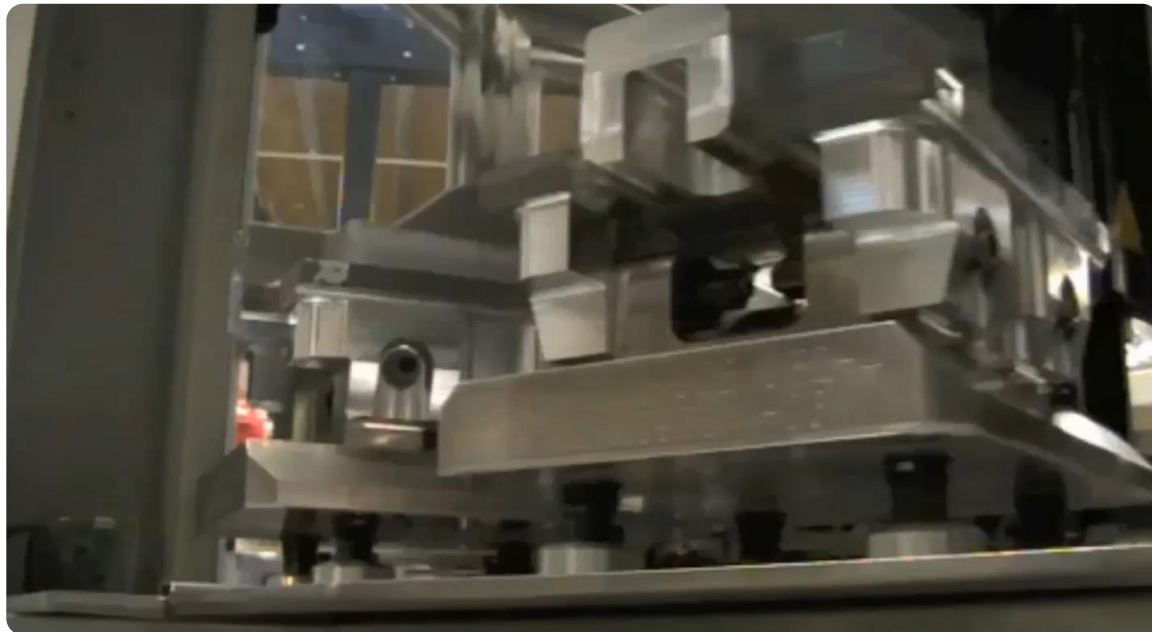
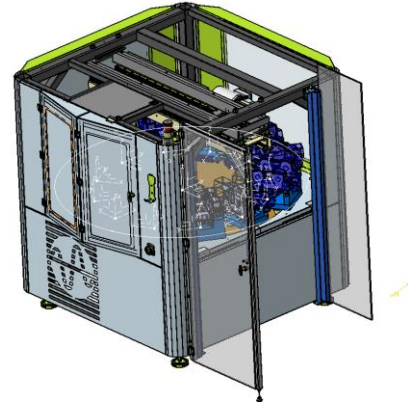

AEROSPACE & DEFENCE, UK

Key Customers/Projects - Military Contracts



Wild Cat



C130-J



A400

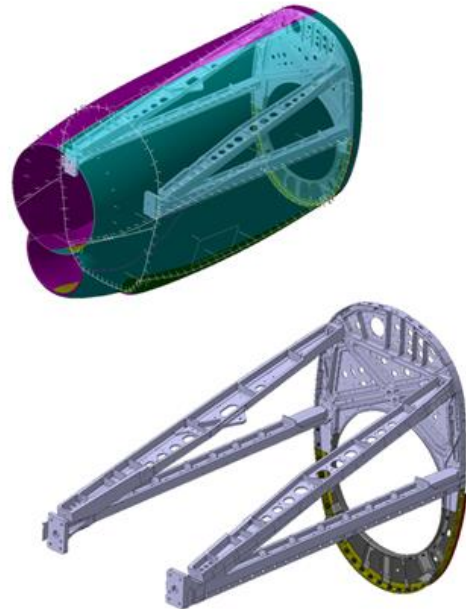

AEROSPACE & DEFENCE, UK

Key Customers/Projects - Commercial Contracts



A320/321 FTB Single Aisle



A330 Variants



MLG



Leading & Trailing Edge

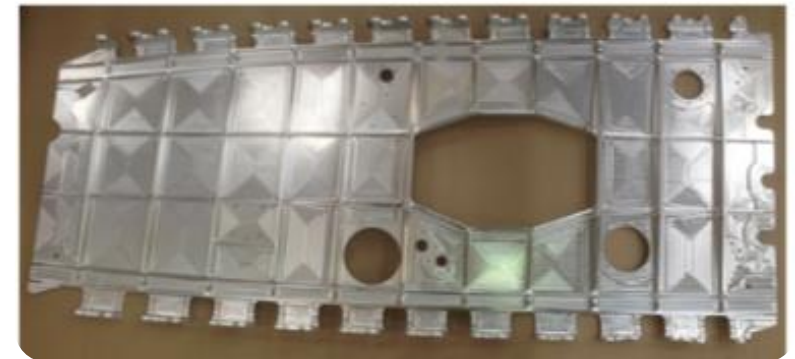
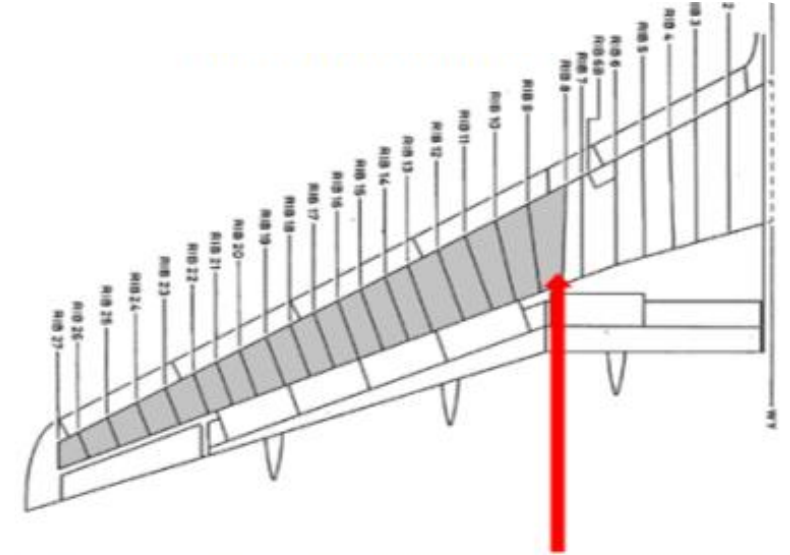

A330 Rib 8

AEROSPACE & DEFENCE, UK

Quality Accreditations



AS 9100:2016 – Page 1



AS 9100:2016 – Page 2



FINANCIAL OVERVIEW

SEGMENT WISE SALES MIX

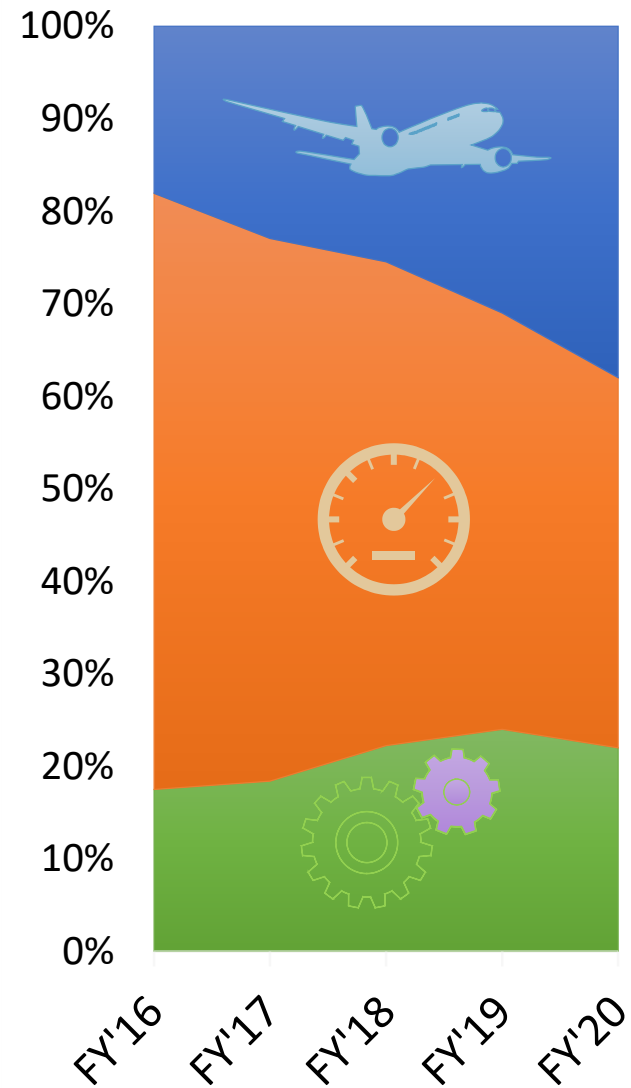

CONSOLIDATED FINANCIAL HIGHLIGHTS



REVENUE BREAK UP

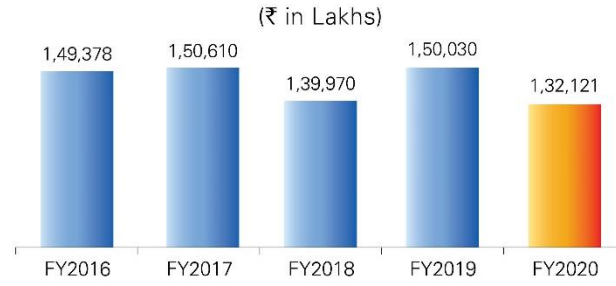

DEBT & LEVERAGE RATIOS

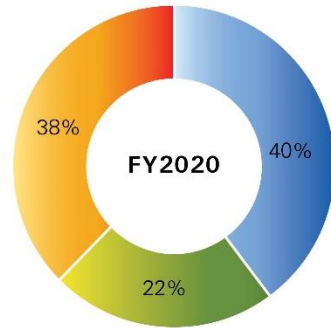
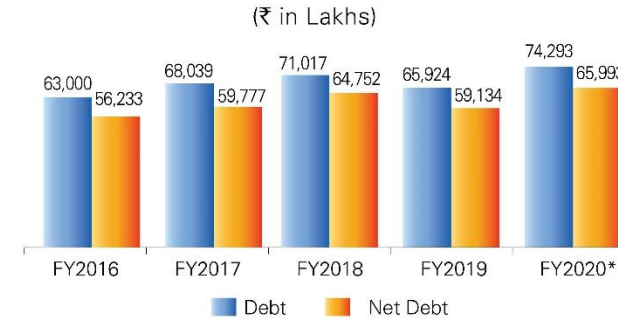

■ Automotive ■ Hydraulics ■ Aerospace & Defence

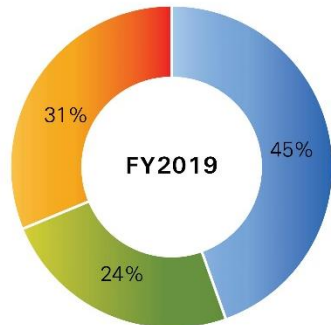

■ Automotive ■ Hydraulics ■ Aerospace & Defence

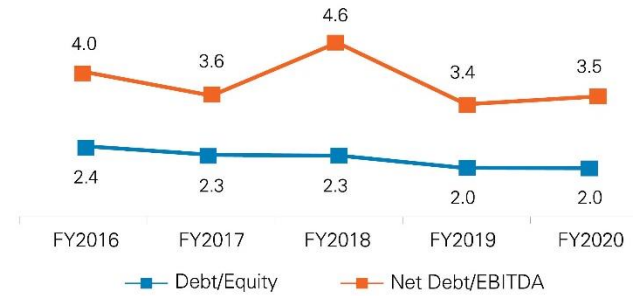



YEARLY FINANCIAL TRENDS

Revenue (Rs. mn) and Growth (Y-o-Y)

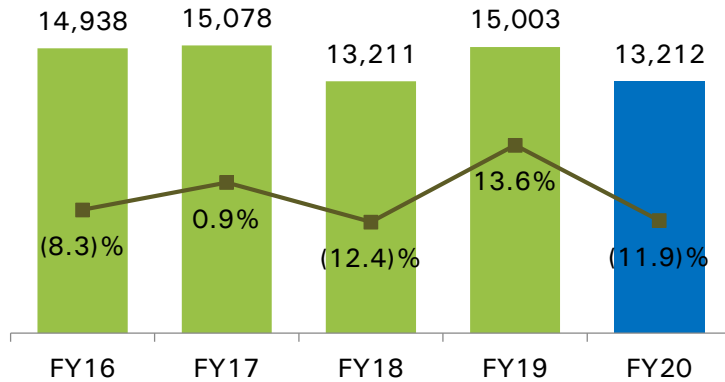

Segment Wise Revenue Contribution

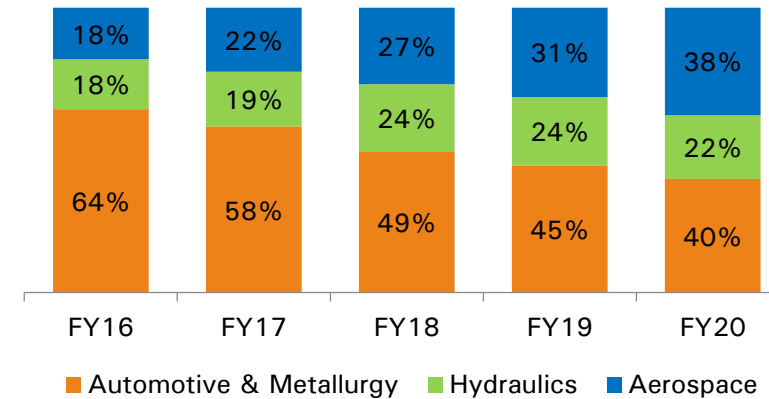

EBITDA (Rs. mn) and Margin (%)

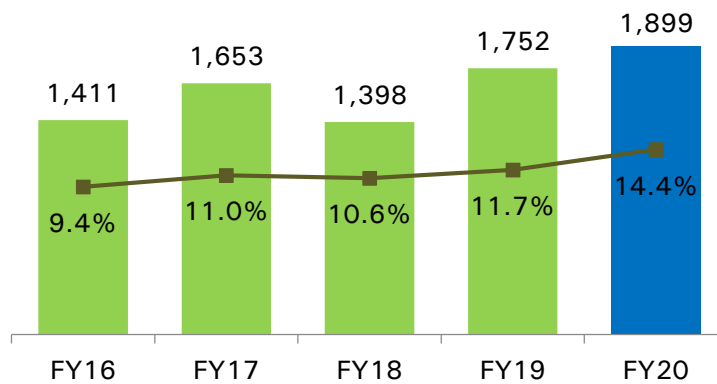

Adjusted EBITDA (Rs. mn) and Margin (%)

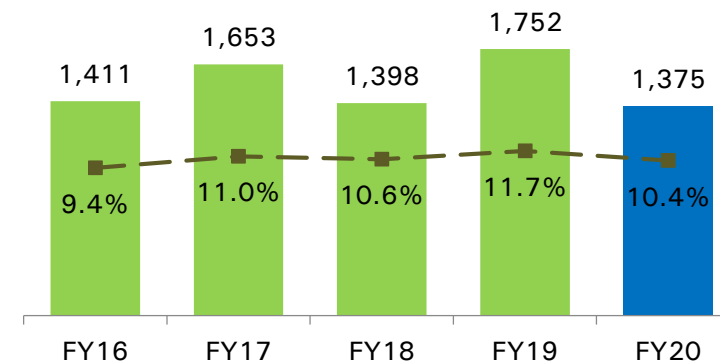

Note:

1. The result / numbers are presented excluding Discontinued operations
2. EBITDA adjusted for the impact of IND AS 116 to make it comparable with corresponding period previous year

QUARTERLY FINANCIAL TRENDS



Capital Structure

(Rs. million)	Jun-19	Sep-19	Dec-19	Mar-20
Long Term	4,300	3,975	3,905	3,876
Short Term	2,276	2,324	2,347	2,200
Operating Lease	1,353	1,416	1,430	1,353
Total Debt	7,929	7,715	7,682	7,429
Less: Cash & Cash Equivalents	509	407	510	830
Net Debt	7,420	7,308	7,172	6,599
Net Worth	3,323	3,357	3,594	3,731

Net Debt/LTM EBITDA & Debt/Equity (x)

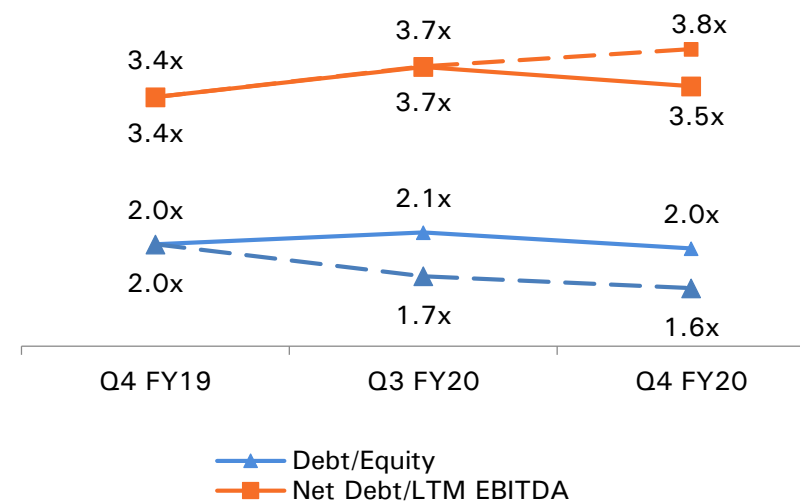

Dotted lines represent the ratios if adjusted for the impact of IND AS 116

Interest Expense (Rs. mn) & Interest Coverage (x)

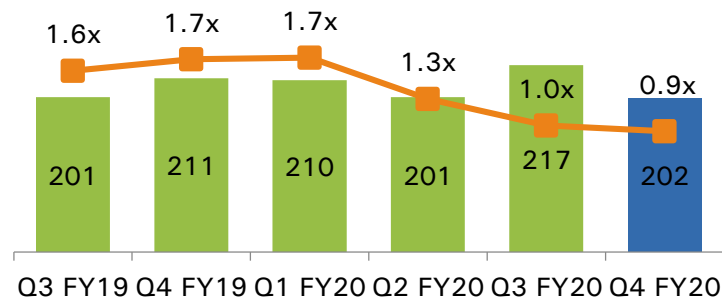

Note: The result / numbers are presented excluding Discontinued operational
 Interest Coverage ratio = Operating Profit / Interest Expense
 Adjusted values reflect impact of IND AS 116

Adjusted Interest Expense (Rs. mn) & Interest Coverage (x)

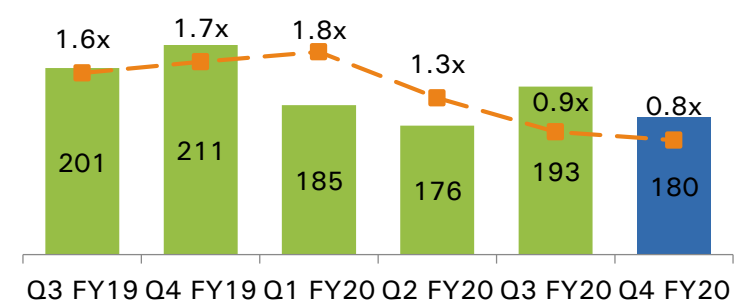

BLUE CHIP INVESTOR BASE



Shareholding Structure

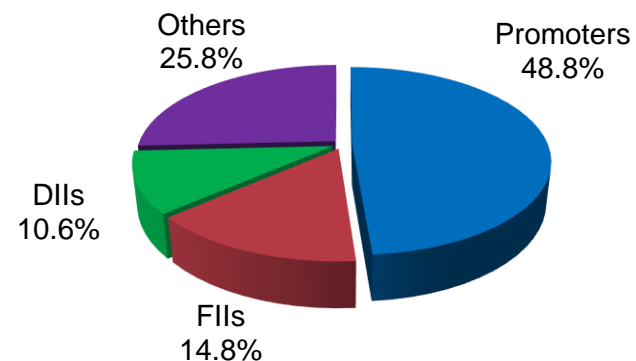

Shareholding Pattern Trend

Shareholders	Jun-19	Sep-19	Dec-19	Mar-20
Promoters	48.8%	48.8%	48.8%	48.8%
FII's	14.8%	14.9%	14.9%	14.8%
DII's	10.8%	10.8%	10.6%	10.6%
Others	25.6%	25.5%	25.7%	25.8%
Total	100.0%	100.0%	100.0%	100.0%

Key Institutional Investors

- HDFC Mutual Fund
- Samena Capital
- Taiyo Greater India Fund
- Alchemy and Group
- Mukul Agarwal and Group
- Girish Gulati - HUF
- SBI Mutual Fund
- Premier Investment Fund

Equity History

Year	Event	Equity Capital (Rs. mn)
1974	Initial Public Offering	2.9
1987	Rights Issue	11.2
1992	Rights Issue	21.0
1994	Rights Issue	31.5
1995	Bonus Issue	41.9
2008	Amalgamation	48.1
2008	Qualified Institutional Placement	54.1
2014	Preferential convertible warrants	60.4
2014	Qualified Institutional Placement	63.4

CONTACT DETAILS



Mr. Chalapathi P

Chief Financial Officer

F: +91 80 2839 5823

E: chalapathi.p@dynamatics.net

Mr. Shivaram V

Head – Legal, Compliance & Company Secretary

F: +91 80 2839 5823

E: shivaram.v@dynamatics.net

DYNAMATIC TECHNOLOGIES LIMITED

Dynamatic Park Peenya Industrial Area

Bangalore 560 058 India

T: +91 80 2839 4933 / 34 / 35

www.dynamatics.net

CIN: L72200KA1973PLC002308

DYNAMATIC TECHNOLOGIES LIMITED

DYNAMATIC TECHNOLOGIES LIMITED

(CIN: L72200KA1973PLC002308)

Dynamatic Park, Peenya Industrial Area, Bangalore 560 058, India

www.dynamatics.net

