

DYNAMATIC TECHNOLOGIES LIMITED

CORPORATE PRESENTATION





DYNAMATIC TECHNOLOGIES LIMITED

CONFIDENTIAL INFORMATION

This presentation contains confidential information regarding Dynamatic Technologies Ltd and its subsidiaries (hereinafter referred to as “Dynamatic” or the “Company”). By accepting this presentation, the recipient enters into the following obligations:

The recipient agrees that it will cause its directors, officers, employees, representatives and advisers to use the information provided in this presentation only to evaluate a specific transaction concerning Dynamatic and its business and for no other purpose.

The Recipient will not divulge any information to any other party without the prior written consent of the Company. Upon the Company’s consent, the recipient shall enter into a confidentiality undertaking with any third party, in particular advisers, that such information is passed on to. Irrespective of the confidentiality undertaking given herein, all other confidentiality undertakings or agreements entered into by the recipient shall remain in full force and effect.

DISCLAIMER

The information contained in this presentation was obtained from the Company and its sources. Any estimates and projections contained herein have been prepared by the management of the Company and involve significant elements of subjective judgement and analysis, which may or may not be correct.

This presentation is confidential, copyright and/or privileged. If you are not the intended recipient, please telephone or email the sender and delete this message. All communication, inquiries and requests pertaining to this presentation and a potential transaction should be directed to:

Mr. Chalapathi P

Chief Financial Officer

F: +91 80 2839 5823

E: chalapathi.p@dynamatics.net



DYNAMATIC TECHNOLOGIES LIMITED

1. Group Overview	4
2. Business Divisions	13
a) Hydraulics	13
• Business Snapshot	14
• Hydraulics, India	15
• Hydraulics, UK	23
b) Automotive & Metallurgy	30
• Business Snapshot	31
• Automotive & Metallurgy, India	32
• Automotive & Metallurgy, Germany	41
c) Aerospace & Defence	46
• Business Snapshot	47
• Aerospace & Defence, India	48
• Aerospace & Defence, UK	58
3. Financial Overview	63



GROUP OVERVIEW



DYNAMATIC TECHNOLOGIES LIMITED

Manufacturers of Highly Engineered Products



- Hydraulics
- Aerospace & Defence
- Automotive





DYNAMATIC TECHNOLOGIES LIMITED

Founded

- 7th March 1973

Registered & Corporate Office Address

- Dynamatic Park, Peenya, Bangalore – 560 058, India
- URL : www.dynamatics.com
- Tel : +91 80 2839 4933 / 34 / 35
- Fax : +91 80 2839 5823
- CIN : L72200KA1973PLC002308

Business Segments & Blue Chip Customers

- **Automotive:** Audi, BMW, Daimler, Ford, Hyundai, Nissan, Tata Motors, Volkswagen
- **Hydraulics:** Caterpillar, Cummins, Eicher, Escorts, John Deere, Mahindra & Mahindra
- **Aerospace and Defence:** Airbus, Bell Helicopter, Boeing, GKN Aerospace, Spirit Aerosystems

Locations

- **India:** 8 Industrial Complexes & 2 Engineering Centers
- **Europe:** 3 Industrial Complexes & 1 Engineering Center

Listed on

- NSE & BSE

Group Revenue

- FY'18 - INR 13,997 Mio

Group EBITDA

- FY'18 - INR 1,324 Mio

Employees

- FY'18 - Over 3,200 worldwide

Patents Held

- 16 (3 awaiting registration)

INR 1 Mio = INR 1,000,000



DYNAMATIC TECHNOLOGIES LIMITED

BUSINESS STRUCTURE

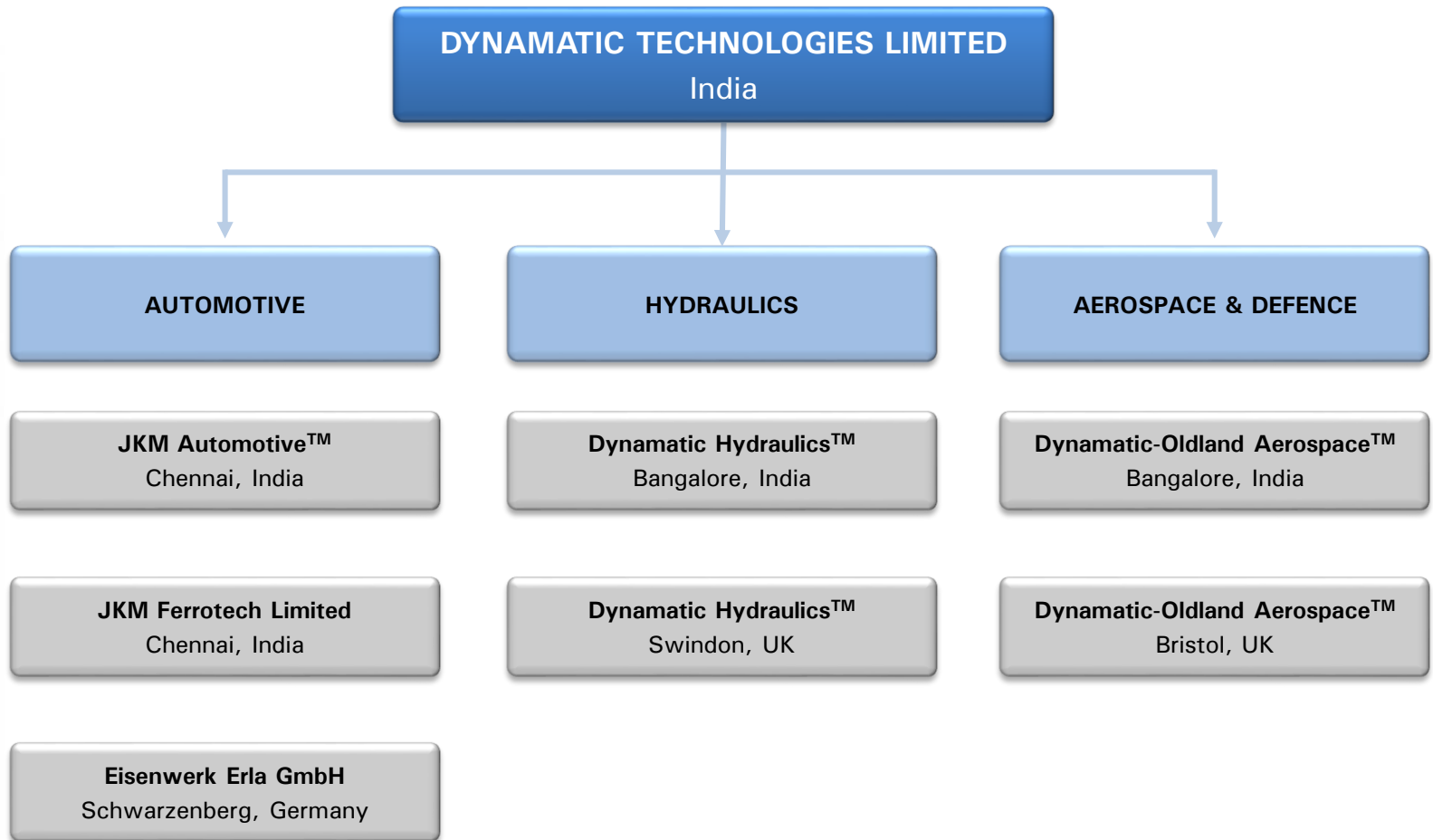



DYNAMATIC TECHNOLOGIES LIMITED

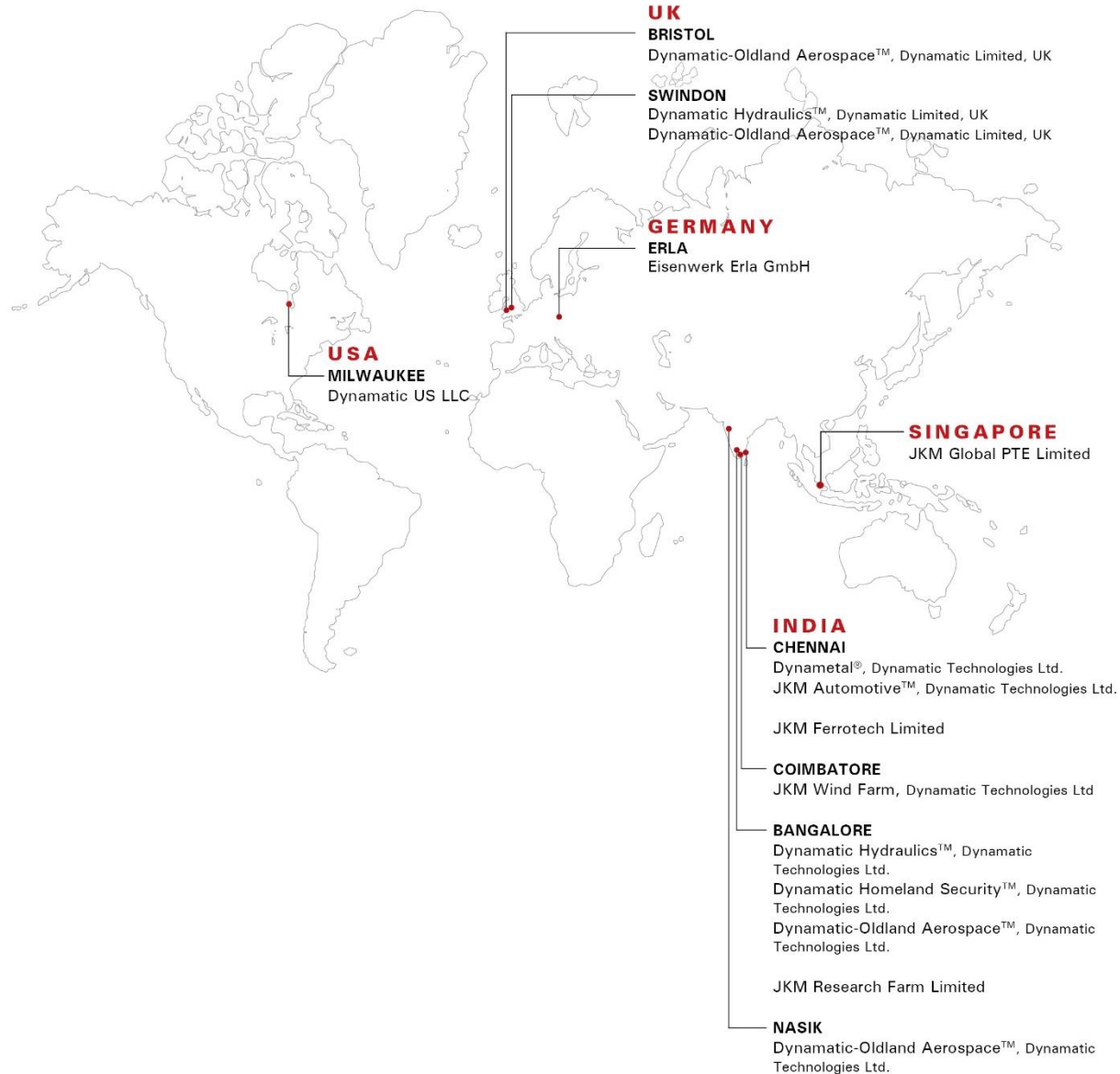



DYNAMATIC TECHNOLOGIES LIMITED

VERTICALLY INTEGRATED MANUFACTURING STRUCTURE

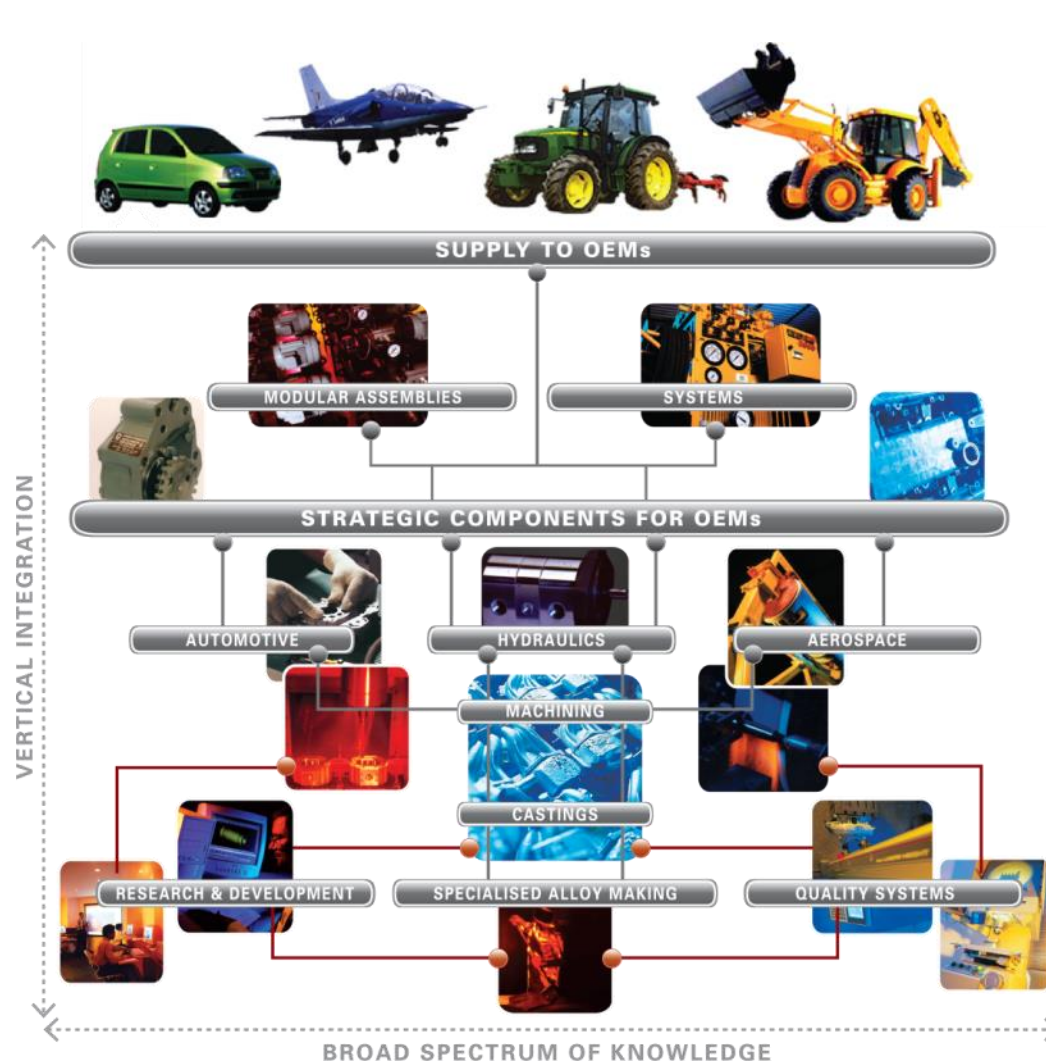



DYNAMATIC TECHNOLOGIES LIMITED

KEY GROWTH MILE STONES

1970-89

1973

Incorporation of Dynamatic Hydraulics Limited

1974

Dynamatic enters into a Technical Collaboration with DOWTY Hydraulic Units Ltd, U.K., for the manufacture of hydraulic elements

1990-99

1991

Dynamatic R&D Center established in Bangalore, India

1992

Dynamatic Hydraulics re-branded as Dynamatic Technologies Limited

1995

Dynametal, Aluminum Foundry, established at Bangalore, India

Dynamatic Aerospace established at Bangalore, India

1998

JKM Daerim[®] Automotive Ltd. established at Chennai, India
Dynametal expanded & moved to Chennai, India

2000-07

2000

Powermetric[®] Design Laboratory established

2005

JKM Global Pte established in Singapore

Dynamatic sets up largest Aerospace facility in Indian Private Sector

2007

Acquisition of manufacturing facilities of Sauer Danfoss Limited, UK, at Swindon through Dynamatic Limited, UK

Dynamatic sets up JKM Science Center, a state-of-the-art design, engineering and R&D facility.

JKM Daerim[®] sets up second manufacturing facility at Chennai, India

Dynamatic buys out minority stake in JKM Dae Rim. Automotive Limited. The subsequently merged automotive unit was rebranded as JKM Automotive[™]

2008-14

2008

Acquisition of JKM Wind Farm, Coimbatore, India

Acquisition of Oldland CNC, Bristol, UK

Dynamatic sets up 'Prana', a modern facility for manufacturing of Airbus A320 Flap Track Beams

2010

Dynamatic inks agreement with Govt. of Karnataka for Aerospace Facility at Devanahalli, India

Dynamatic Homeland Security established

2011

Acquisition of Eisenwerk Erla GmbH, Germany, & Sanmar Ferrotech Ltd.

2012

KIADB allots 27 acres to Dynamatic at the Devanahalli Aerospace Park, Bangalore, for Aeronautic Manufacturing Facility

2013

Decentralisation of Indian Hydraulics Operations into Two Main Manufacturing Units & Two Ancilliary Units.

Expansion of Aerospace Facilities in India and UK



DYNAMATIC TECHNOLOGIES LIMITED

KEY GROWTH MILE STONES

2015

Dynamatic Hydraulics™

- Signed 3 year Long Term Supplier Agreement with John Deere, Moline, Illinois US.A.
- Achieved British Standards Institute (BSI) Certificate of Registration for Quality Management System ISO 9001:2008 which expires in 2018.
- Passed the Supplier Quality Audit undertaken by MacDon Industries Limited based in Winnipeg, Canada
- Made it's first foot print in USA by opening it's first overseas operational premise.
- Made it's entry into Indian Railways business and expanded the product offerings to the Indian Defence segment

Start for extension of the core-shop-department by around 2000 m² to stabilize/implement production of steel castings in Erla

Dynamatic - Oldland Aerospace™, India Delivers FAI for Boeing Chinook Ramp & Pylon Assembly

2016

Achieved the highest level of Partner status with John Deere in their Achieving Excellence Awards.

Inauguration of First Machining Facility in Erla

Dynamatic - Oldland Aerospace™, UK installs a dynamic automation line from EROWA which is 30m long connected to Five 5 axis machine.

Dynamatic - Oldland Aerospace™, UK construction for additional expansion started at Swindon site for the new Machine

Handing over of commercial production of the A330 beams in presence of **UK Prime Minister Rt. Hon Theresa May**

2017

Inauguration of Dynamatic Aerotropolis by Bell Team on Feb 15th 2017

Inauguration of the DMC340 by Airbus team. Proving of Support frame and MSP software on 4th May 2017

Approval of AS 9100 (ISO 9001:2008) certified by Novo Star for Aerotropolis

Dispatch of 1000th set Airbus 321 Flap-Track-Beams on 13th June 2017

Handing over of 100th Ship Set of Sukhoi-30 MKI Assemblies to Hindustan on 9th Dec 2017 Aeronautics Limited

2018

Dynamatic received 'Supplier Appreciation Award 2018' from Boeing Defense, Space & Security for Supplier Performance on 14th March 2018.

FAI of Bell 407 Lower Aft Fuselage for Bell Helicopter completed on 20th April 2018



DYNAMATIC TECHNOLOGIES LIMITED

CORPORATE STRUCTURE

BOARD OF DIRECTORS



Nalini Ranjan Mohanty
 Director, DTL
 Chairman of Finance Committee
 Chairman of Stakeholders' Relationship Committee
 Chairman of Technology Development and Strategy Committee
 Chairman of Audit and Risk Management Committee
 Member of Nomination and Remuneration Committee
 Member of Corporate Social Responsibility Committee
 Director, JKM Ferrotech Limited
 Director, JKM Eris Automotive Limited



Govind Mirchandani
 Chairman, DTL
 Chairman of Corporate Social Responsibility Committee
 Chairman of Audit & Risk Management Committee
 Member of Stakeholders' Relationship Committee
 Member of Nomination & Remuneration Committee
 Member of Share Transfer Committee
 Member of Technology Development and Strategy Committee
 Director, JKM Ferrotech Limited
 Director, JKM Eris Automotive Limited



Malavika Jayaram
 Director, DTL
 Chairman of Nomination & Remuneration Committee
 Member of Finance Committee
 Member of Technology & Strategy Development Committee
 Member of Corporate Social Responsibility Committee



Udayant Malhoutra
 CEO & Managing Director, DTL
 Chairman of Share Transfer Committee
 Member of Technology & Strategy Development Committee
 Member of Stakeholders' Relationship Committee
 Member of Finance Committee
 Chairman, JKM Global Pte Ltd, Singapore
 Chairman, Dynamatic Ltd, UK
 Chairman, Yew Tze Investments Ltd, UK
 Geschäftsführer, Eisenwerk Eris GmbH, Germany



Dietmar Hahn
 Director, DTL
 Member of Technology & Strategy Development Committee
 Geschäftsführer
 Eisenwerk Eris GmbH



Lt Gen Sarjeer Madhok (Retd.)
 FVSM, AVSM, VSM
 Head of Defence Business



Chalapathi P
 Chief Financial Officer, DTL
 Chief Financial Officer, JKM Eris Automotive Limited
 Director, JKM Automotive Limited



Junko Sebastian
 Director
 JKM Ferrotech Limited



Enrico Fischer
 Finance Director & Chief Financial Officer
 Eisenwerk Eris GmbH



Arvind Mishra
 Executive Director & Global Chief Operating Officer, Dynamatic Hydraulics™
 Head of Dynamatic Homeland Security™
 Managing Director, Dynamatic Hydraulics™, Dynamatic Limited UK
 Member of Technology & Strategy Development Committee
 Member of Finance Committee



P S Ramesh
 Executive Director & Chief Operating Officer, Dynamatic-Oldland Aerospace™, India
 Member of Audit & Risk Management Committee
 Member of Technology Development Committee
 Member of Finance Committee



James Tucker
 Director, DTL
 Member of Technology Development Committee
 Managing Director
 Aerospace Division, Dynamatic Limited, UK



Pramila Malhoutra
 Director, JKM Global Pte Limited
 Director, JKM Eris Automotive Limited
 Director, JKM Research Farm Limited



Geoff Dore
 CFO, UK & Group Treasurer
 Director, Eisenwerk Eris GmbH, Germany



Naven Chandra
 Head Legal, Compliance & Company Secretary, DTL
 Member of Share Transfer Committee
 Director, JKM Global FTE Ltd.



A Karan
 Deputy Chief Operating Officer
 JKM Automotive™ & Dynamatic™



Chandra Mohan Reddy V
 Sr. General Manager - Manufacturing
 Hydraulics Division, India



Darren Fisher
 General Manager, Hydraulics Division
 Dynamatic Limited, UK



Ravichander V
 Deputy COO
 Dynamatic Oldland Aerospace™, India



Jagpal Singh
 Head of Engineering
 Aerospace, India



Steve Hayes
 Technical Director
 Aerospace Division
 Dynamatic Limited, UK



Suresh J Naras
 Vice President, Corporate Affairs
 (Asset Management) DTL
 Director, JKM Ferrotech Limited
 Director, JKM Research Farm Limited
 Director, JKM Automotive Limited



Nitin Ajage
 GM, Corporate Accounting, DTL



Saresh Kumar R
 Vice President, Operations
 JKM Ferrotech Limited



M Senthil Kumar
 GM, Marketing
 JKM Auto & JFTL



P K Ray Chaudhuri
 Head of Engineering
 DTL Research & Development



Joe Hatt
 Engineering Manager
 Hydraulics Division,
 Dynamatic Limited, UK



Air Cmde (Retd.) Saini Deo vasi
 General Manager,
 Aerospace Division,
 Aerospace Nashik



Darren Bancroft
 General Manager
 Aerospace Division,
 Dynamatic Limited, UK



M Mohanavel
 Head of Global Machining
 JKM Global Pte Ltd.



Lakshmi Kamath
 CFO, JKM Ferrotech Limited



Jaynagpal Gajendra
 GM, Corporate Treasury, DTL
 Financial Controller,
 Hydraulics, India

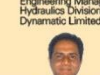

Pradeep Shankar
 General Manager - Head of Strategic Sourcing
 Hydraulics, India



Padmanabhan C
 General Manager - Supplier Quality Management
 Aerospace, India



Ajay Gurusu
 Head - Business Development & CRM
 Aerospace, India

SENIOR MANAGEMENT



DYNAMATIC TECHNOLOGIES LIMITED

PARTNERS

Auditors

- B S R & Co. LLP STATUTORY
- Ernst & Young INTERNAL

Credit Rating / Equity Research Agencies

- ICRA Limited
- India Ratings & Research Pvt Ltd

Business Scope Report

- Dun & Bradstreet

Lead Bankers

- Axis Bank Limited
- Bank of India
- Commerz bank
- Deutsche Leasing
- Export-Import Bank of India
- ICICI Bank Limited
- IndusInd Bank Limited
- Kotak Mahindra Bank Limited
- Sachsen Bank
- Siemens Financial Services Pvt. Ltd.
- The Royal Bank of Scotland
- Tata Capital
- DMG MORI Finance
- TARGO Leasing



BUSINESS DIVISIONS
HYDRAULICS



DYNAMATIC TECHNOLOGIES LIMITED

BUSINESS SNAPSHOT

Brand Names	<ul style="list-style-type: none">• Dynamatic Hydraulics™
Locations	<ul style="list-style-type: none">• Bangalore, India and Swindon, UK
Key Customers	<ul style="list-style-type: none">• Mahindra & Mahindra, John Deere, SAME, Case New Holland, Cummins
Revenue	<ul style="list-style-type: none">• FY'18 - INR 3,111 Mio
EBITDA	<ul style="list-style-type: none">• FY'18 - INR 372 Mio
Competitive Market Position	<ul style="list-style-type: none">• One of the world's top producers of hydraulic gear pumps• Leadership in Hydraulic Gear Pumps market for 40 years• Design & Development partnerships with major global Tractor OEMS
R&D	<ul style="list-style-type: none">• Owns design IP of all products• Largest number of product variants in the world

INR 1 Mio = INR 1,000,000



DYNAMATIC TECHNOLOGIES LIMITED

HYDRAULICS, INDIA

- Dominant Player in the Indian Market - 65% share of the India organized tractor market
- Global Reach: Supplier of choice to leading Tractor OEMs including John Deere, CNH, Claas, Agco & Same Deutz-Fahr
- Comprehensive Range of Gear Pumps for all applications
- Growth Drivers: Agriculture, Infrastructure & Energy sectors
- Technology Leadership - Among the World's finest Engineering Laboratories
- High Quality



DYNAMATIC TECHNOLOGIES LIMITED

HYDRAULICS, INDIA

Facilities

Location : Bangalore, India



Dynamatic Hydraulics™,
Unit I



Dynamatic Hydraulics™,
Unit II



Dynamatic Hydraulics™,
Unit III

- 3 Manufacturing Units in Peenya Industrial Area, Bangalore



DYNAMATIC TECHNOLOGIES LIMITED

HYDRAULICS, INDIA

R&D / Engineering

- Comprehensive R&D Capabilities
- Advanced Endurance & Performance
- Testing Facilities including SCADA
- Digital Design, Rapid Prototyping
- Engineering Laboratory certified as 'Recognized In-House R&D Unit' by Dept. of Scientific & Industrial Research (DSIR), Government of India





DYNAMATIC TECHNOLOGIES LIMITED

HYDRAULICS, INDIA

Product Offerings

Aluminum Body Pumps

For Agricultural Equipment & Industrial Applications



Cast Iron Gear Pumps

For Construction Equipment & Earth Moving Equipment





DYNAMATIC TECHNOLOGIES LIMITED

HYDRAULICS, INDIA

Product Offerings

Cummins Lube Oil Pump



Quadruple Pump

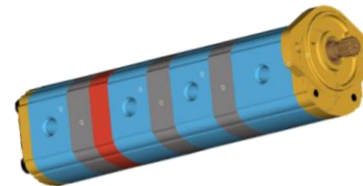

Tractor Hitch Control Valves

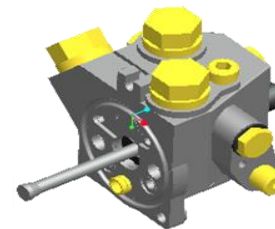
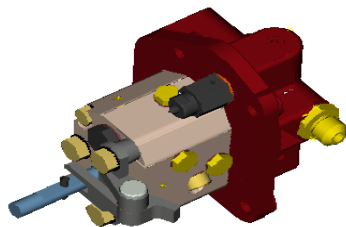



DYNAMATIC TECHNOLOGIES LIMITED

HYDRAULICS, INDIA

Product Offerings

Rockshaft Assembly

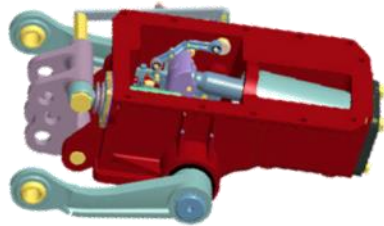

Built To Print Tractor Control Valves



Various Applications



**Lube Oil Pump
Marine Applications**



Gear Motor



Internal Gear Pump



Medium Pressure Pump



DYNAMATIC TECHNOLOGIES LIMITED

HYDRAULICS, INDIA

Key Customers

- Mahindra & Mahindra Limited
- John Deere
- SAME Deutz-Fahr
- New Holland
- Eicher Motors
- Cummins India Limited
- Escorts
- Tractors And Farm Equipment Limited (TAFE)
- Caterpillar Inc
- CNH
- Voltas
- Force Motors Ltd.
- AGCO



DYNAMATIC TECHNOLOGIES LIMITED

HYDRAULICS, INDIA

Quality/EMS Certifications



ISO 9001



ISO 14001



DYNAMATIC TECHNOLOGIES LIMITED

HYDRAULICS, UK

- Six decades of engineering and manufacturing excellence.
- Acquired by Dynamatic Technologies in 2007
- Products include performance engineered hydraulics products such as aluminium and cast Iron gear pumps, fan drive system, engineered packages, etc
- Supplier of choice to leading Global Tractor OEMS including John Deere and Case New Holland
- Technology Leadership - Among the World's finest Hydraulic Design Laboratories
- High Quality and Lean Focus





DYNAMATIC TECHNOLOGIES LIMITED

HYDRAULICS, UK

Facilities

Location : Swindon, UK



Dynamatic Hydraulics™
Dynamatic Limited, UK





DYNAMATIC TECHNOLOGIES LIMITED

HYDRAULICS, UK

R&D / Engineering

- Possesses Advanced design knowledge for Mobile Hydraulics Sector
- Comprehensive Product Testing and validation capabilities





DYNAMATIC TECHNOLOGIES LIMITED

HYDRAULICS, UK

Product Offerings

Aluminum Body Hydraulic Gear Pumps and Integrated Gear/Piston Pump Packages



Cast Iron Gear Pumps





DYNAMATIC TECHNOLOGIES LIMITED

HYDRAULICS, UK

Product Offerings

Fan Drive Motor, Integrated Control Valve and Tandem Gear Pump



Engineered Packages

High Value-add Products combining Multiple Pump & Valve Elements in a compact unit





DYNAMATIC TECHNOLOGIES LIMITED

HYDRAULICS, UK

Key Customers

- John Deere
- Muncie® Power Products
- Alexander Dennis
- White House Products Ltd
- CNH
- Termhope Limited – UK Distributor



DYNAMATIC TECHNOLOGIES LIMITED

HYDRAULICS, UK

Quality Accreditations

- Accredited to the British Standards Institute Quality Management System, ISO 9001 2008
- Approved as Partner by John Deere
- Approved supplier to ADL, Terex Limited & ZF
- Member of the BFPA



ISO 9001 2008



BUSINESS DIVISIONS
AUTOMOTIVE & METALLURGY



DYNAMATIC TECHNOLOGIES LIMITED

BUSINESS SNAPSHOT

Brand Names

- JKM Automotive™
- Dynametal®
- Eisenwerk Erla GmbH
- JKM Ferrotech™

Locations

- Chennai, India and Schwarzenberg, Germany

Key Customers

- Audi, BMW, Daimler, Ford, Hyundai, Nissan, Tata Motors, Volkswagen

Revenue

- FY'18 - INR 7,323 Mio

EBITDA

- FY'18 - INR 185 Mio

Competitive Market Position

- Produces highly engineered automotive components for highway, off-highway and technology oriented applications
- One of the world's largest manufacturers of automotive turbochargers
- Single source supplier to global OEMS for selected products

INR 1 Mio = INR 1,000,000



DYNAMATIC TECHNOLOGIES LIMITED

AUTOMOTIVE & METALLURGY, INDIA

- Producer of high quality Aluminium and Ferrous components for Automotive applications
- **Single Source** to Global Auto OEMs for critical engine & transmission components - catering to over 50% of Indian Passenger Car Market
- Strategically Located in Chennai, one of India's leading Automotive Hubs
- Stable Supply Chain due to Backward Integration – JKM Automotive™ insources Aluminium castings from Dynametal® & Ferrous castings from JKM Ferrotech™



DYNAMATIC TECHNOLOGIES LIMITED

AUTOMOTIVE & METALLURGY, INDIA

Facilities

Location : Chennai, India



JKM Automotive™

- Supplies automotive components such as engine, transmission, chassis and turbocharger parts
- Backward integrated for supply of aluminium and iron castings
- Capacity: 10.8 million parts



JKM Ferrotech Limited

- Manufactures high precision, complex metallurgical ferrous castings for automobile engines and turbochargers
- Compliant with ISO 9001 and TS16949 standards and approved by BMW, Hyundai and Toyota
- Capacity: 26,000 MTPA



Dynametal®

- Supplies non-ferrous alloys and castings for industrial, automotive and aerospace applications
- Eco-friendly foundry equipped with electric furnaces, shot blasting, impregnation & heat treatment facilities
- Capacity: 4,380 MTPA



DYNAMATIC TECHNOLOGIES LIMITED

AUTOMOTIVE & METALLURGY, INDIA

R&D/Engineering

Magma Casting Simulation

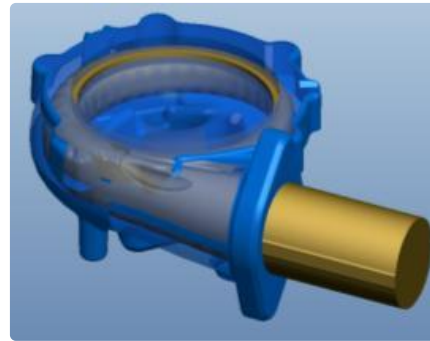
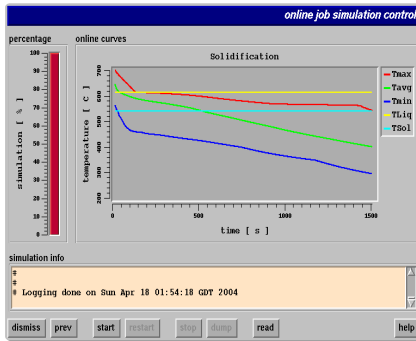
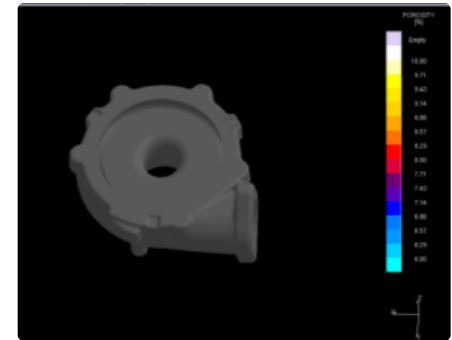
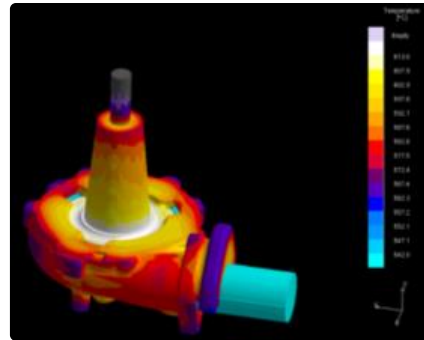
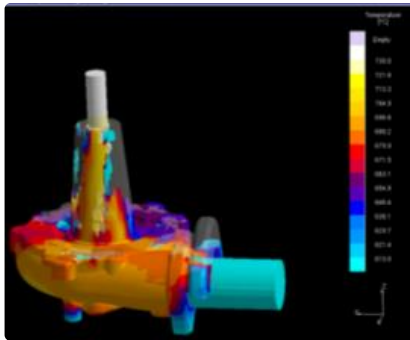

- Development of thin wall castings
- Capable of executing Aluminum Gravity Die Cast parts with intricate contours.
- Complex core assembly
- “Cast in” oil ways and galleries
- Competence in alloying metals and complex castings.



DYNAMATIC TECHNOLOGIES LIMITED

AUTOMOTIVE & METALLURGY, INDIA

Product Offerings

Engine & Transmission Parts



Exhaust Manifold Assy.

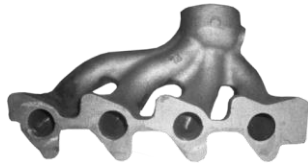

Inlet Manifold

Air Tube assembly

Water Pump



Oil Pump



Fork Shift



Rocker Arm (A&B)



Chasis Parts



DYNAMATIC TECHNOLOGIES LIMITED

AUTOMOTIVE & METALLURGY, INDIA

Product Offerings



Flywheel (VW)



Brake Caliper (Mando)



**Lanchester Housing
(Daimler)**



Brake Mounting Plate



Bracket



**Turbocharger Center
bearing housing**



End Yoke



**Compressor
Mounting Bracket**



DYNAMATIC TECHNOLOGIES LIMITED

AUTOMOTIVE & METALLURGY, INDIA

Product Offerings



**Compressor Housing
(Honeywell)**



**Compressor Housing
(Honeywell)**



**Fork shift
(Getrag Ford)**



**Inlet Manifold
(Hyundai)**



**Air tube inlet
(Renault Nissan)**



**Fork shift
(Getrag Ford)**



DYNAMATIC TECHNOLOGIES LIMITED

AUTOMOTIVE & METALLURGY, INDIA

Key Customers

- Volkswagen
- Man SE
- BMW
- Daimler AG
- Hyundai Motor Company
- Mando Corporation
- Honeywell Garrett
- Tata Motors
- Ford Motor Company
- Cummins
- Renault–Nissan



DYNAMATIC TECHNOLOGIES LIMITED

AUTOMOTIVE & METALLURGY, INDIA

Quality Accreditations



OHSAS 18001:2007



ISO 14001:2004



DYNAMATIC TECHNOLOGIES LIMITED

AUTOMOTIVE & METALLURGY, GERMANY

Eisenwerk Erla GmbH

- 600 year old history of iron extraction and processing; One of the finest ferrous foundries in Europe
- Manufacturer of ferrous and special alloy castings. Products include Turbine housings, Exhaust Manifolds, Crankshaft Bearing Caps & other Automotive Castings
- Specialisation in high-grade alloys such as SiMo, Ni-Resist, Heat Resistant Steel and Core Making Technology of Turbocharger castings
- Over 12.5% share of Global Petrol Turbocharger market





DYNAMATIC TECHNOLOGIES LIMITED

AUTOMOTIVE & METALLURGY, GERMANY

Facilities

Location : Schwarzenberg, Germany



Eisenwerk Erla GmbH





DYNAMATIC TECHNOLOGIES LIMITED

ADVANCED ROBOTIC MANUFACTURING



IN GERMANY

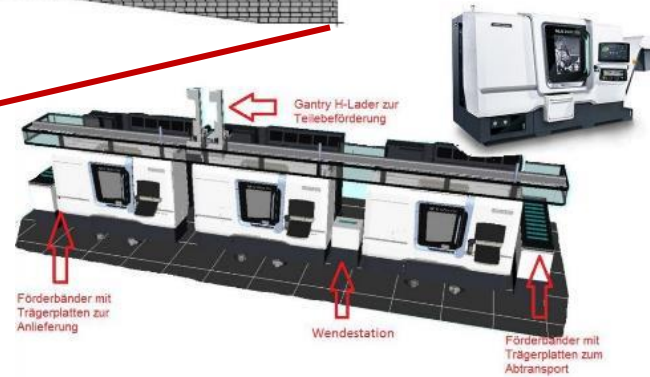
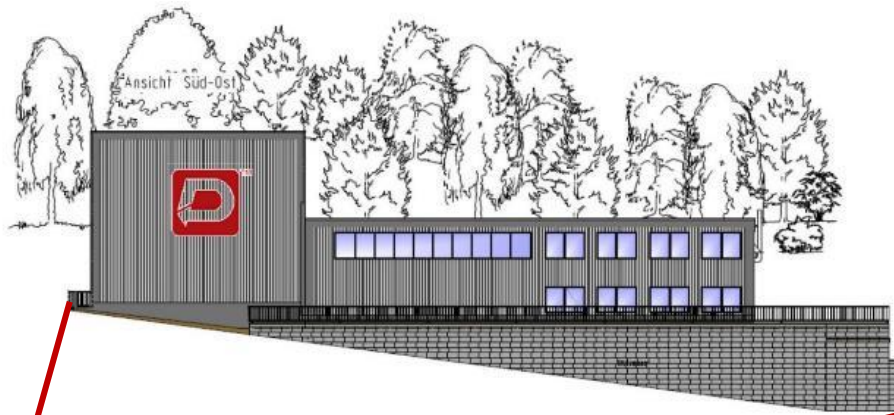



DYNAMATIC TECHNOLOGIES LIMITED

AUTOMOTIVE & METALLURGY, GERMANY

Product Offerings

Turbine Housings



Crankshaft Bearing Cap



For Use In Turbo Charged Engines





DYNAMATIC TECHNOLOGIES LIMITED

AUTOMOTIVE & METALLURGY, GERMANY

Key Customers

- IHI Charging Systems International
- Bosch Mahle Turbo Systems
- Volkswagen
- BorgWarner Turbo & Emissi
- Voegele
- Man SE
- BMW
- Mercedes-Benz
- Audi
- Voith
- Daimler AG



DYNAMATIC TECHNOLOGIES LIMITED

AUTOMOTIVE & METALLURGY, GERMANY

Quality, Environmental & Energy Accreditations



ISO-TS 16949:2009



DIN EN ISO 14001:2004



ISO 50001-2011



DYNAMATIC TECHNOLOGIES LIMITED

AUTOMOTIVE & METALLURGY, GERMANY

Research & Development

- Strong R&D capabilities and Patented Technologies specific to the Automotive Industry
- Collaboration with major German technical institutes – Technical University of Freiberg, West Saxon University of Applied Sciences of Zwickau Germany and InnCoa





BUSINESS DIVISIONS
AEROSPACE & DEFENCE



DYNAMATIC TECHNOLOGIES LIMITED

BUSINESS SNAPSHOT

Brand Names

- Dynamatic-Oldland Aerospace™
- Dynamatic Homeland Security™

Locations

- Bangalore & Nasik - India, Bristol & Swindon - UK

Key Customers

- Airbus, Boeing, Bell Helicopter, Spirit AeroSystems, GKN, Dassault Aviation, Hindustan Aeronautics Limited

Revenue

- FY'18 - INR 3,563 Mio

EBITDA

- FY'18 – INR 814 Mio

Competitive Market Position

- Demonstrated leader for the development of exacting Air Frame Structures and Precision Aerospace Components
- Tier I supplier to Airbus, Boeing and Bell Helicopter
- Delivers high value to customers by combining technical competence of the UK facilities with the cost and manufacturing advantages offered by the Indian facilities



DYNAMATIC TECHNOLOGIES LIMITED

AEROSPACE & DEFENCE, INDIA

- Pioneer and demonstrated leader in the Indian private sector for manufacture of high precision airframe structures and aerospace components
- Largest infrastructure in the Indian private sector, possesses stringent regulatory approvals and quality certifications that present significant barriers to entry
- Strong Partnerships with MoD and agencies of national importance like DRDO, HAL, NAL, etc
- Only Indian Company to be a Tier One Supplier to Airbus, Boeing and Bell Helicopter
- Also provides security solutions to India's national defence forces, homeland security forces, police and civilian agencies.



DYNAMATIC TECHNOLOGIES LIMITED

AEROSPACE & DEFENCE, INDIA

Facilities

Location : Bangalore, India





DYNAMATIC TECHNOLOGIES LIMITED

AEROSPACE & DEFENCE, INDIA

Key Customers/Projects



Lakshya Pilotless Target Aircraft
Products: Wings & Rear Fuselage.



HJT 36 Intermediate Jet Trainer
Products: Ailerons & Flaps



Sukhoi 30 MKI Fighter Bomber
Products: Vertical Fins, Slats, Cannards, Stabilisers, Air Brakes, and Ventral Fins

Hindustan Aeronautical Limited



DYNAMATIC TECHNOLOGIES LIMITED

TEJAS LIGHT COMBAT AIRCRAFT FUSELAGE

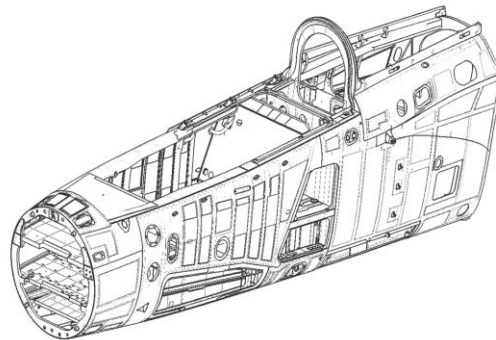
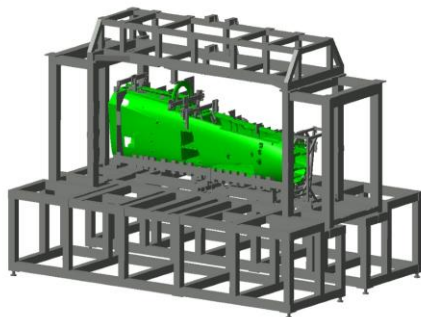
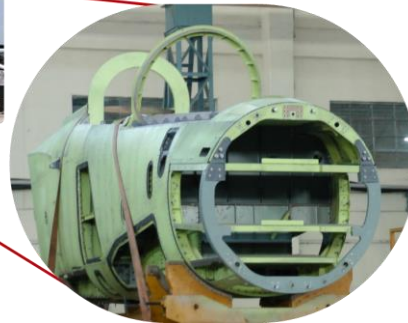

Dynamatic Technologies Limited has been chosen as the supplier for the Front Fuselage assembly from HAL - Light Combat Aircraft Division



DYNAMATIC TECHNOLOGIES LIMITED

AEROSPACE & DEFENCE, INDIA

Key Customers/Projects

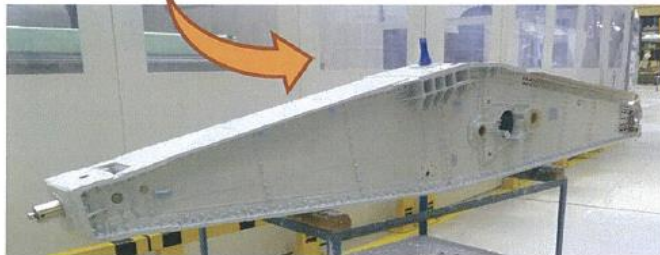
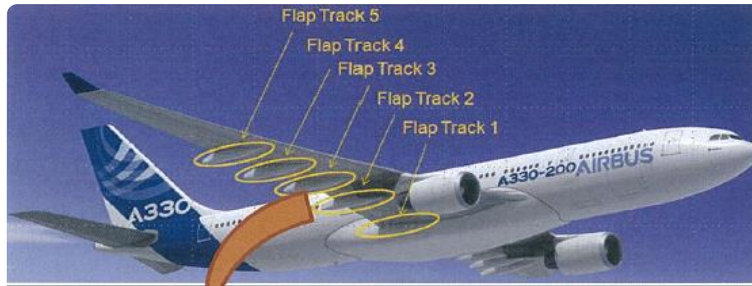

Airbus A330

Centre of Excellence for Airbus Flap Track Beams

Manufacturing 100% of Airbus Single Aisle

Contracted for 100 % of all Airbus Long Range



Airbus A320/A321



DYNAMATIC TECHNOLOGIES LIMITED

AEROSPACE & DEFENCE, INDIA

Key Customers/Projects

Boeing Chinook

Cargo Ramp Assembly Aft Pylon

Boeing P8

Mission & Power Cabinets





DYNAMATIC TECHNOLOGIES LIMITED

AEROSPACE & DEFENCE, INDIA

Key Customers/Projects

Major Assemblies to build
Bell Helicopters 407
Item – 30 Cabin assembly

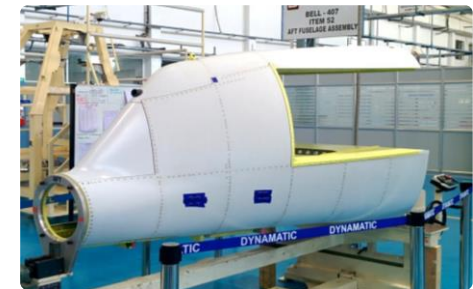
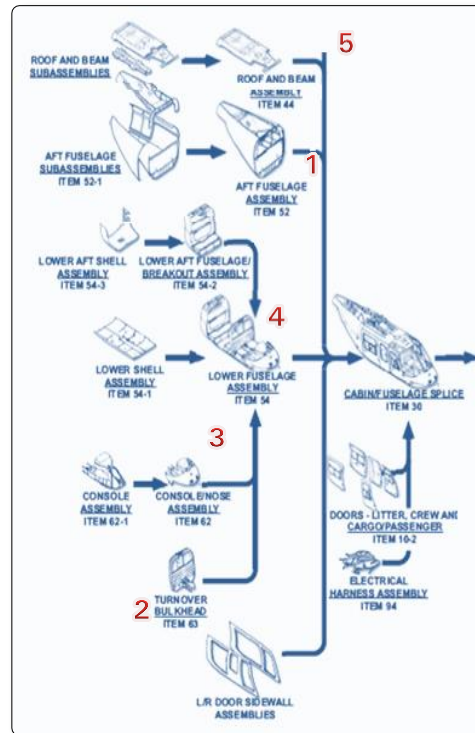
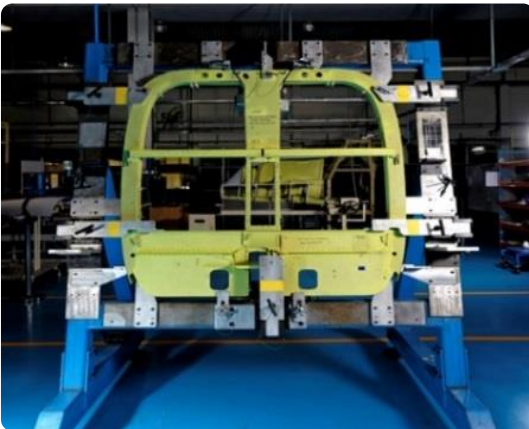



DYNAMATIC TECHNOLOGIES LIMITED

AEROSPACE & DEFENCE, INDIA

Awards & Accolades



Dr. APJ Abdul Kalam, Dr. K.G. Narayanan,
Udayant Malhoutra (*LtoR*)

1999



Creative Partner Award for the year
1998-99 awarded by DRDO, ADE
and ASIEO

2000



National Award for excellence in indigenisation of
defence equipment by Ministry of Defence



DYNAMATIC TECHNOLOGIES LIMITED

CONSISTENTLY HAL'S BEST SUPPLIER

Awards & Accolades

2003

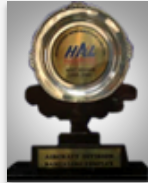

HAL Best Vendor Award for 2002-03 by HAL's aircraft division

2008



Outstanding Vendor Award for 2008 by HAL

2013



Best Supplier Award for 2013 by HAL

2015



2016



2017





DYNAMATIC TECHNOLOGIES LIMITED

AEROSPACE & DEFENCE, INDIA

Quality Accreditations

- AS9100, DGAQA and NADCAP approved
- Quality approval from Airbus, Boeing, Bell Helicopters, HAL
- DGAQA approval for In-house Processes
- ISO 9001:2000 certified by UL
- AS 9100 Rev D certified
- Entire Campus ISO 14001 approved by Lloyds
- NADCAP approval for NDT, Heat Treatment, Welding Facilities, Metrology
- ISO 27001: 2013 approval Information Security Management System



ISO 27001



AS 9100



NADCAP for Heat Treatment



NADCAP for NDT



NADCAP for Welding



NADCAP for Metrology



DYNAMATIC TECHNOLOGIES LIMITED

AEROSPACE & DEFENCE, INDIA

Homeland Security



IBMS Solutions



Un-Manned Ground Vehicle*

*(Conceptual stage - picture taken from Wikipedia)

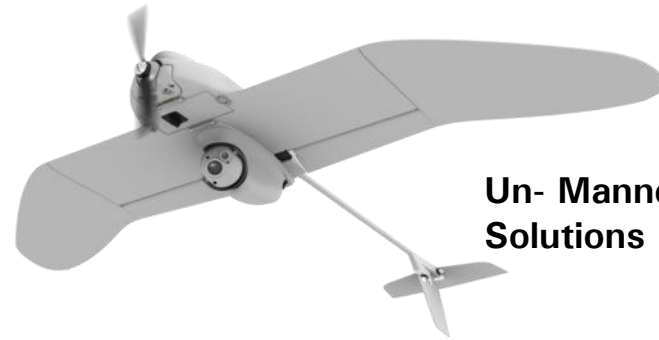

Un- Manned Aerial Solutions

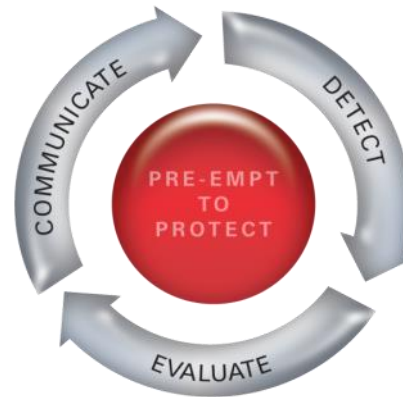

Mobile Command & Control Vehicle



DYNAMATIC TECHNOLOGIES LIMITED

AEROSPACE & DEFENCE, UK

- High End Precision Engineering company manufacturing components and tooling for Aerospace industry
- Complex 5 axis machining capabilities for the manufacture of a vast range of machining, finishing, assembly and inspection operations to world-class standards
- Acquired by Dynamatic in 2008
- Long term contracts with OEM's & Tier1 suppliers
- Certified supplier to Airbus UK, Boeing, GKN Aerospace, Magellan Aerospace, GE Aviation Systems, Lockheed Martin, Agusta Westland, Spirit AeroSystems, UK

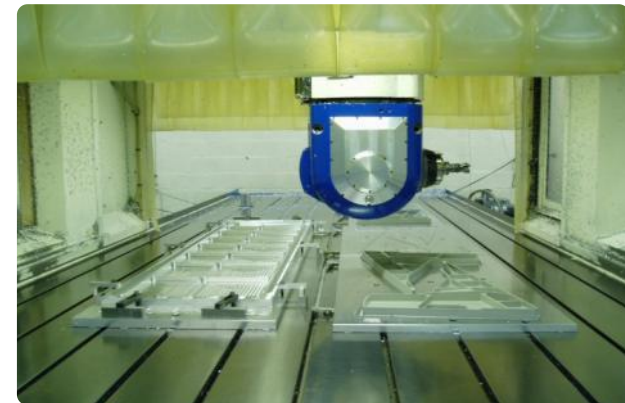



DYNAMATIC TECHNOLOGIES LIMITED

AEROSPACE & DEFENCE, UK

Facilities

Location : Bristol & Swindon UK



Bristol



Swindon





DYNAMATIC TECHNOLOGIES LIMITED

FULLY AUTONOMOUS **ROBOTIC MANUFACTURING**

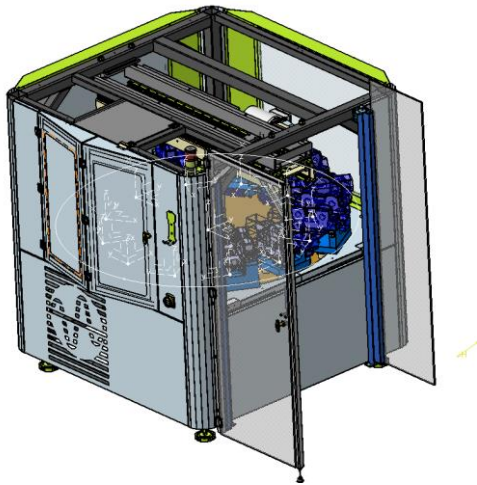



DYNAMATIC TECHNOLOGIES LIMITED

AEROSPACE & DEFENCE, UK

Key Customers/Projects - Military Contracts

Wild Cat



C130-J



A400M

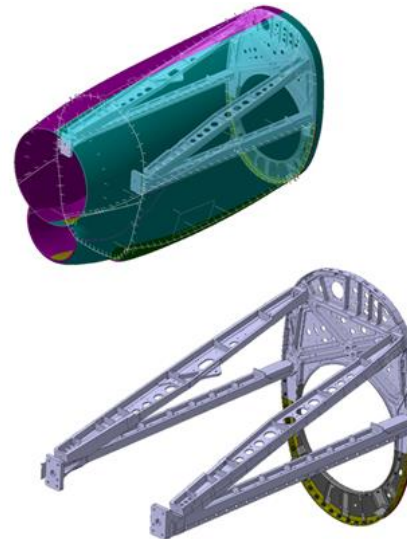
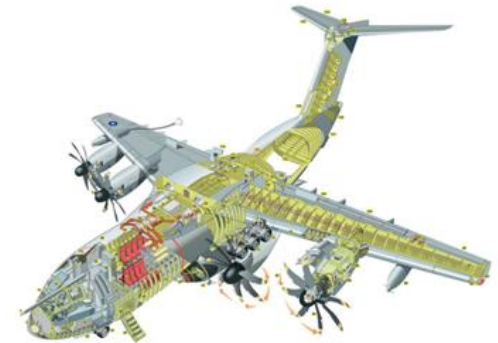



DYNAMATIC TECHNOLOGIES LIMITED

AEROSPACE & DEFENCE, UK

Key Customers/Projects - Commercial Contracts

A320/321 FTB Single Aisle



A330 Variants



MLG



Leading & Trailing Edge



Rib Manufacture

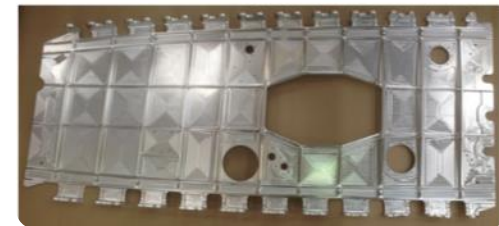
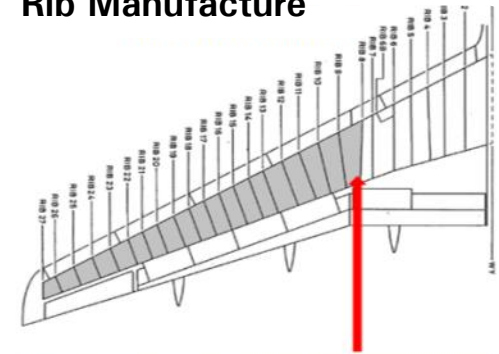

A330 Rib 8



DYNAMATIC TECHNOLOGIES LIMITED

AEROSPACE & DEFENCE, UK

Quality Accreditations



AS9100 REV C & 9001:2008



ISO 14001:2004



GKN Aerospace



AIRBUS Certification



SPIRIT AeroSystems



Westland



Aerostructures Hamble Ltd.



DYNAMATIC TECHNOLOGIES LIMITED

AEROSPACE & DEFENCE, UK

Key Customers

- Airbus
- GKN Aerospace
- Spirit AeroSystems
- Northrop Grumman
- Boeing
- Dassault Aviation



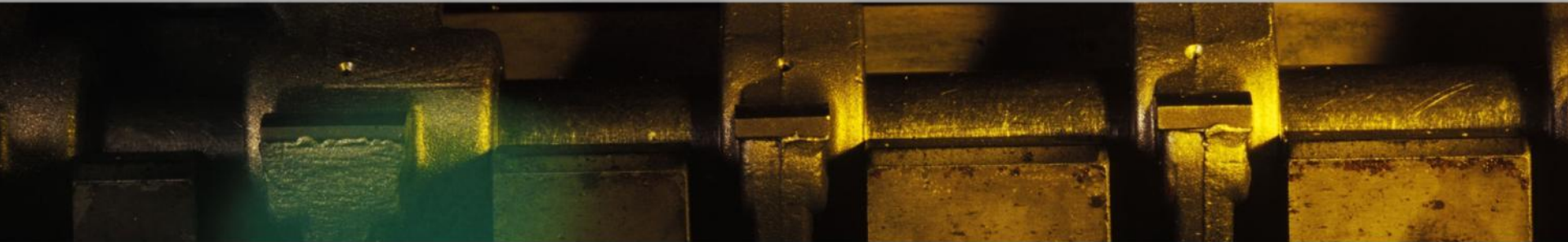

FINANCIAL OVERVIEW



DYNAMATIC TECHNOLOGIES LIMITED

GLOBAL REACH

IN 2006-2007

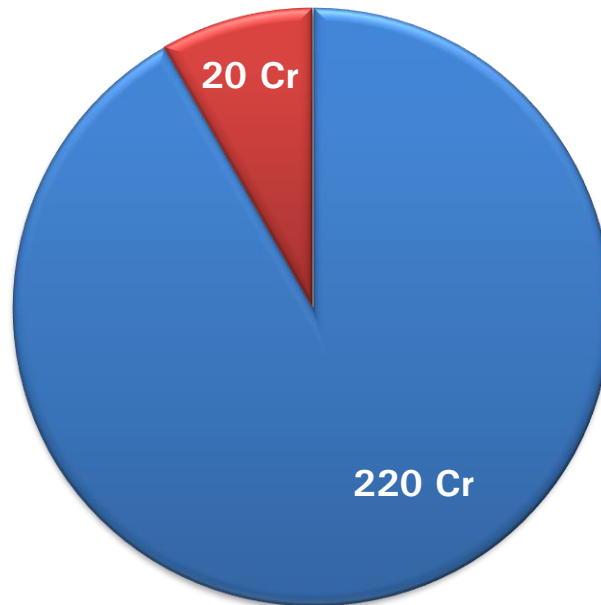

■ Local ■ Global

IN 2017-2018

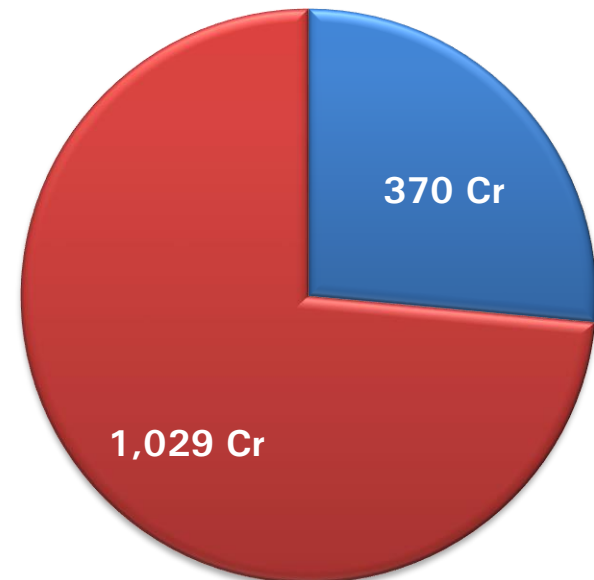

■ Local ■ Global

Rupees in Crores (Cr)



DYNAMATIC TECHNOLOGIES LIMITED

DIVISIONAL SALES MIX

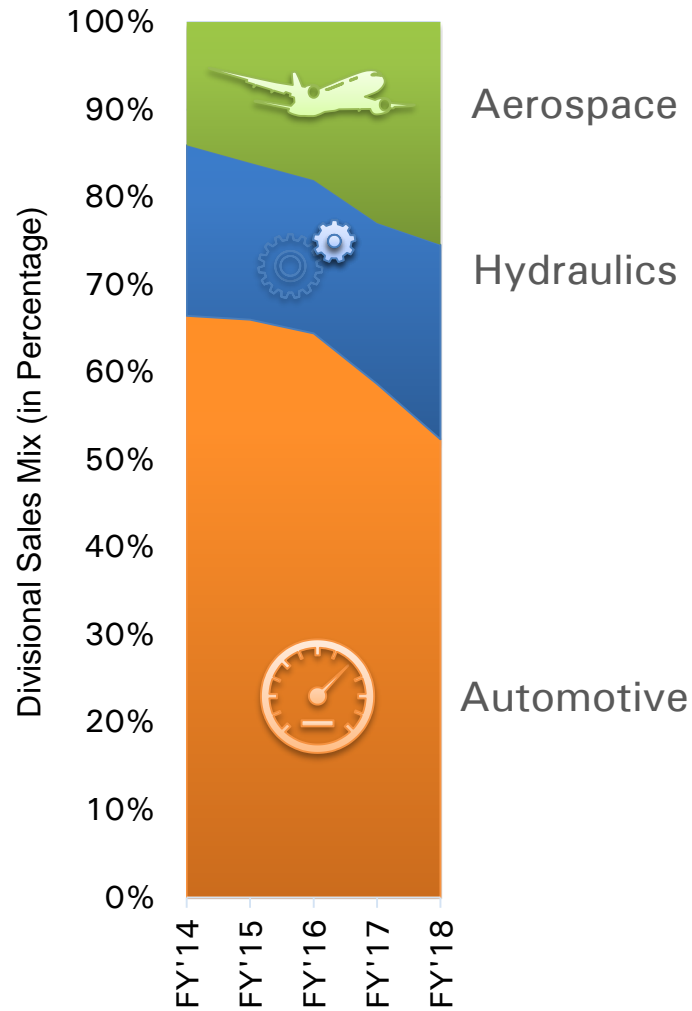



DYNAMATIC TECHNOLOGIES LIMITED

CONSOLIDATED FINANCIAL HIGHLIGHTS

REVENUE BREAK UP

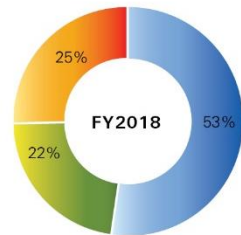
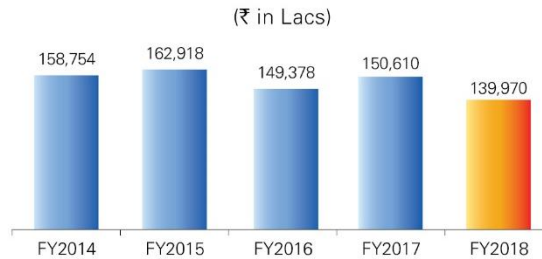

■ Automotive ■ Hydraulics ■ Aerospace & Defence

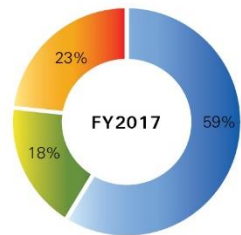

■ Automotive ■ Hydraulics ■ Aerospace & Defence

DEBT & LEVERAGE RATIOS

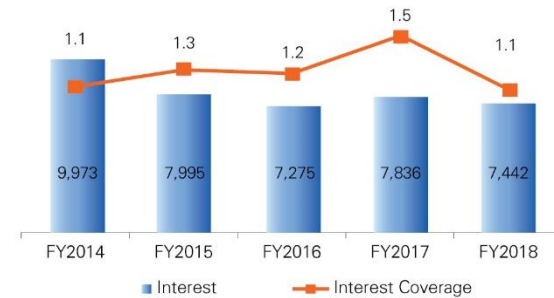
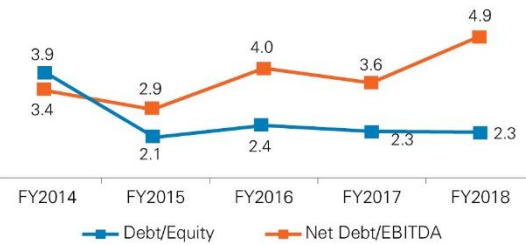
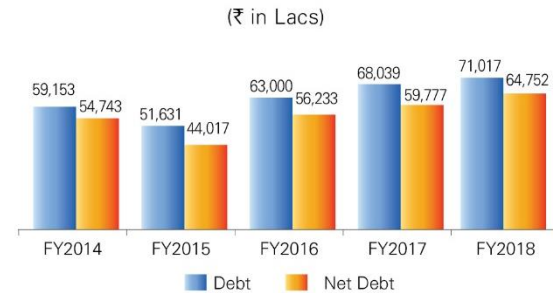



DYNAMATIC TECHNOLOGIES LIMITED

QUARTERLY FINANCIAL TRENDS

Revenue (Rs. mn) and Growth (Q-o-Q)

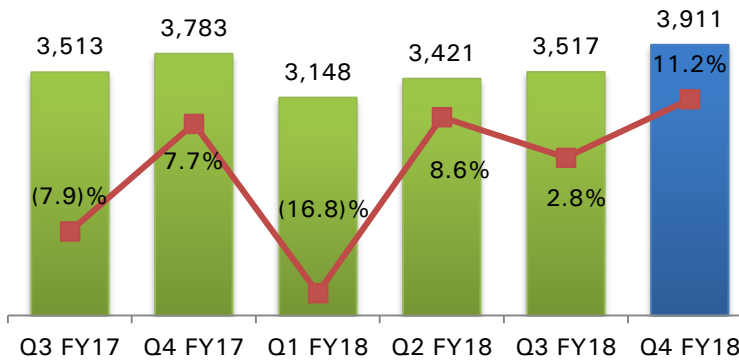

Segment Wise Revenue Contribution

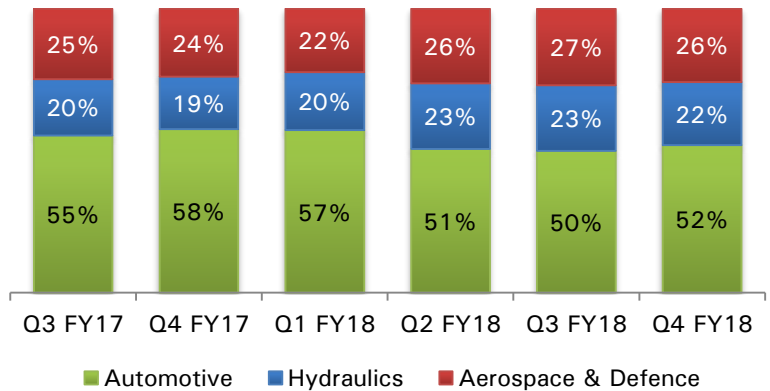

EBITDA (Rs. mn) and Margin (%)

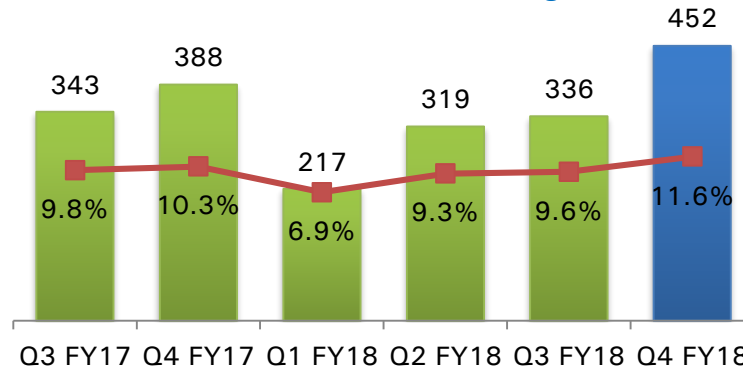

Note: Financials for FY18 and FY17 are Ind-AS based



DYNAMATIC TECHNOLOGIES LIMITED

QUARTERLY FINANCIAL TRENDS

Capital Structure

(Rs. million)	Mar 31, 2018	Dec 31, 2017
Long Term Borrowings	4,893	4,763
Short Term Borrowings	2,209	2,243
Total Debt	7,102	7,006
Less: Cash & Cash Equivalents	627	520
Net Debt	6,475	6,486
Net Worth	3,138	3,255

Interest Expense (Rs. mn) & Interest Coverage (x)

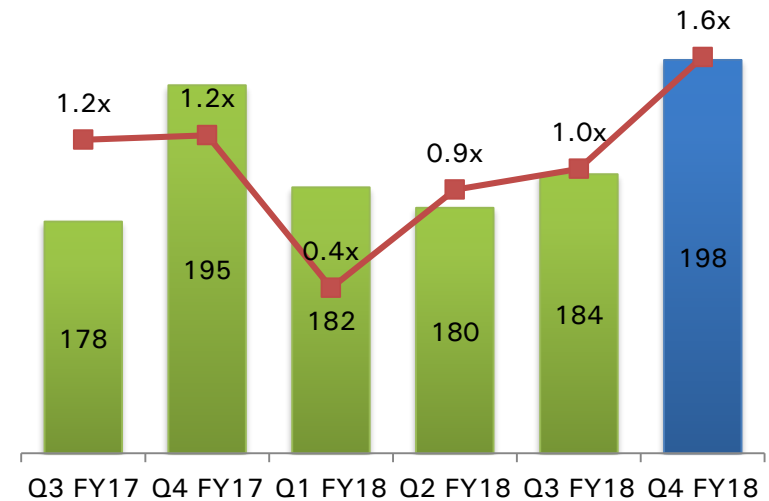

Net Debt/LTM EBITDA & Debt/Equity (x)

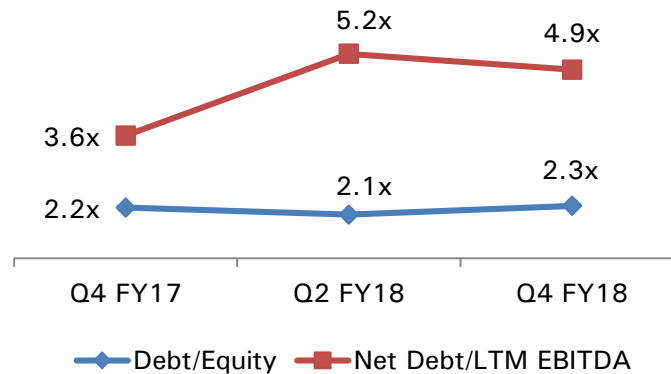

Note: Interest Coverage ratio = Operating Profit / Interest Expense



DYNAMATIC TECHNOLOGIES LIMITED

BLUE CHIP INVESTOR BASE

Shareholding Structure

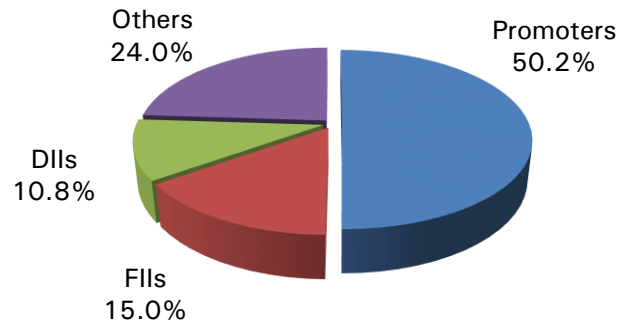

Key Institutional Investors

- Samena Capital and Citi Group
- HDFC Mutual Fund
- Alchemy and Group
- Goldman Sachs Group
- SBI Mutual Fund
- Mukul Agarwal and Group
- Taiyo Greater India Fund
- Premier Investment Fund
- Cyril Traders
- L& T Mutual fund

Shareholding Pattern Trend

Shareholders	Sep-17	Dec-17	Mar-18
Promoters	50.2%	50.2%	50.2%
FII's	14.8%	15.0%	15.0%
DII's	12.4%	12.2%	10.8%
Others	22.6%	22.6%	24.0%
Total	100.0%	100.0%	100.0%

Equity History

Year	Event	Equity Capital (Rs. mn)
1974	Initial Public Offering	2.9
1987	Rights Issue	11.2
1992	Rights Issue	21.0
1994	Rights Issue	31.5
1995	Bonus Issue	41.9
2008	Amalgamation	48.1
2008	Qualified Institutional Placement	54.1
2014	Preferential convertible warrants	60.4
2014	Qualified Institutional Placement	63.4



DYNAMATIC TECHNOLOGIES LIMITED

CONTACT DETAILS

Mr. Chalapathi P

Chief Financial Officer

F: +91 80 2839 5823

E: chalapathi.p@dynamatics.net

Mr. Shivaram V

Head – Legal, Compliance & Company Secretary

F: +91 80 2839 5823

E: shivaram.v@dynamatics.net

Dynamatic Technologies Limited

Dynamatic Park

Peenya Industrial Area

Bangalore 560 058

India

T: +91 80 2839 4933 / 34 / 35

www.dynamatics.net

CIN: L72200KA1973PLC002308

DYNAMATIC TECHNOLOGIES LIMITED

DYNAMATIC TECHNOLOGIES LIMITED

(CIN: L72200KA1973PLC002308)

Dynamatic Park, Peenya Industrial Area, Bangalore 560 058, India

www.dynamatics.net

