

Dynamatic Technologies Ltd® Hydraulic gear motor, Model:1DR Hydraulic Gear Pump

Salient Features

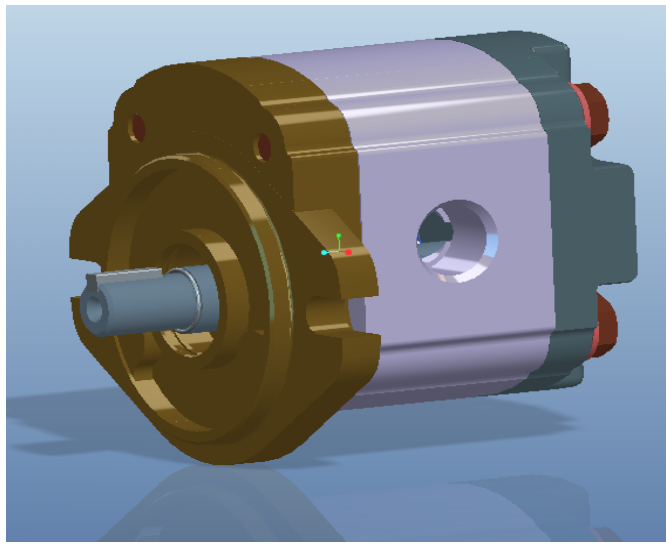

Dynamatic gear motors has a range of uni and bi-rotational high performance gear motors to meet the needs of both mobile and industrial market sectors. These units are available with wide choice of flow sizes, installation features and performance variables.

Gear motors are offered in a range of displacement from 6.0cm³/rev to 27 cm³/rev. Motors are available in two and three port versions and the company specializes in supplying units to special order instructions (subject to quantity).

High volumetric efficiencies produced by Dynamatic motors are achieved in part by careful attention to control of gear tip leakage. The body to gear geometry is arranged such that during the running in test cycle, to which every unit is subjected, the gears cut perceptible tracks in the body. This results in virtually zero clearance between the gear tips and body producing a near perfect tip seal under running conditions.

Floating composite bushes are used which house the bearing liners and provide a face seal to the gears. This efficient seal is achieved by pressure loading precise areas of the bush rear face with fluid at working pressure. Specially developed and patented bush seals prevent high pressure entering the drain system around and between the journal bearings, in addition to separating high and low pressure areas at the bush rear face.

All motors and pumps have the same advanced pressure balancing system that effectively satisfies the conflicting requirements of bush loading resulting from uni and bi-rotational units when they are connected in single or series mode. the pressure balancing system ensures a minimum nett on load mechanical efficiency, yet the same time balancing system ensures a minimum nett on-load for high mechanical efficiency ,yet at the same time balancing varying pressure distribution across the bush face .Thus contributing to high volumetric performance of gear pump and motors.

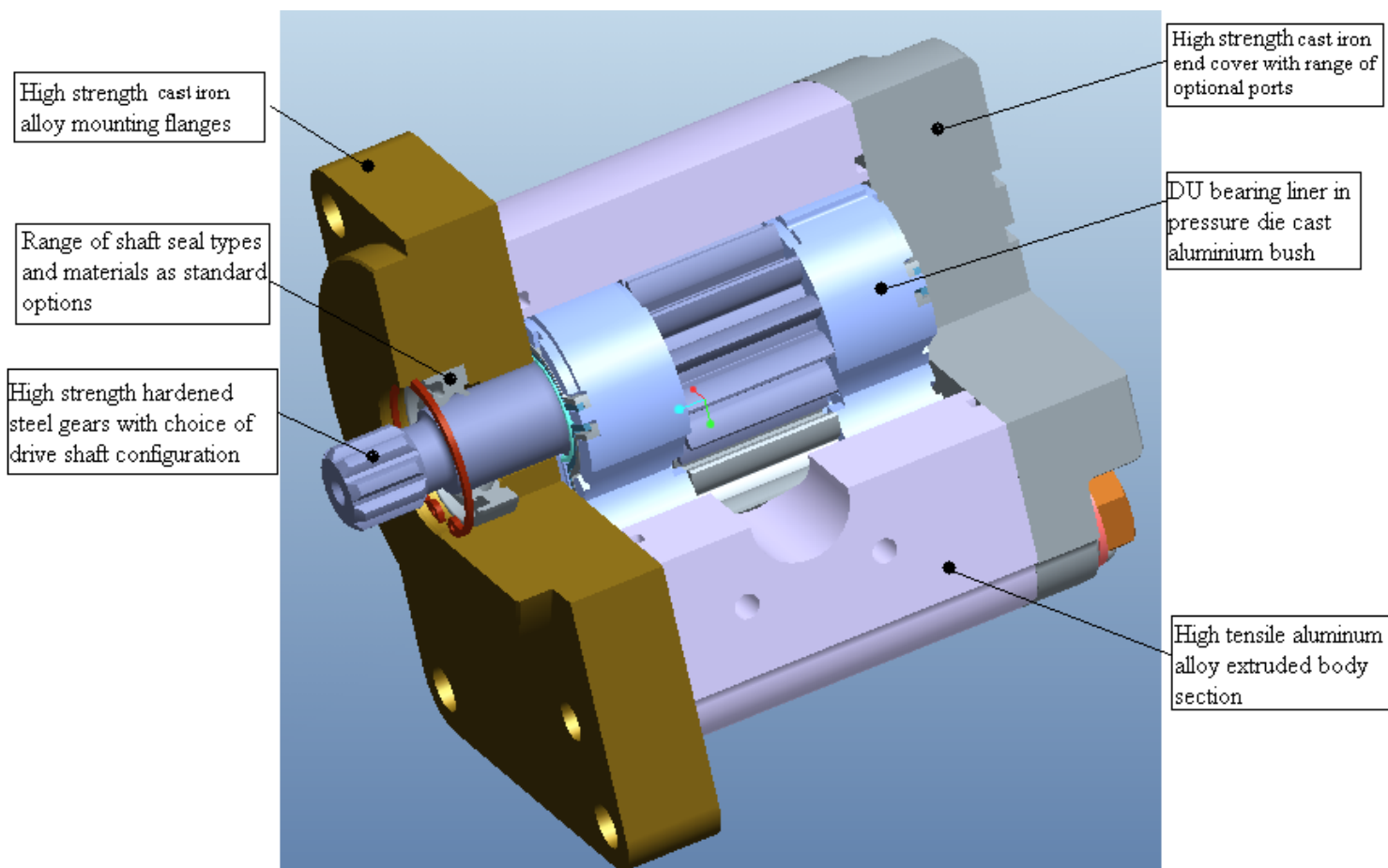



PERFORMANCE

High duty journal bearings are essential for motors and pumps delivering levels of performance attained by Dynamatic pumps and motors. PTFE/lead (DU) plain bearings are used throughout to sustain high journal loads when operating at pressures of 250 bar and speeds of 300-3500 rev/min.

The dry run properties of DU bearings are particularly valuable during initial start-up conditions and contribute to the motors high starting torque performance. To complement these bearings, Dynamatic has developed special journal surface finishes and treatments to obtain the maximum benefits from this bearings configuration.

A 12 teeth configuration was chosen for the pumps and motors as this gave an optimum performance against physical size relationship. The motor has an excellent low speed rating combined with a high starting torque and low output torque ripple. In pump form, the use of 12 teeth gives the benefit of lower fluid borne noise and hence a quieter hydraulic system together with lower tooth contact stresses promoting a longer working life.

DURABILITY

High tensile aluminium alloy extruded bodies are used throughout the range to ensure uniformity in material properties and maximum fatigue strength. Through body bores enable precise alignment of the bearings and hence maximum bearing load capacity. Careful attention to detail machining and surface promotes an extended operating life.

Dynamatic pumps and motors units have been designed to perform with a wide range of fluids and can be supplied with nitrile and viton seals as standard.



PERFORMANCE DATA

MOTOR TYPE	THEORETICAL DISPLACEMENT	MAXIMUM CONTINUOUS PRESSURE P1		SPEED AT PRESSURE P1 rev/min		TYPICAL MAXIMUM RUNNING TORQUE AT PRESSURE P1	
	cm ³ /rev	bar	psi	min	max	Nm	lbf.ft
1DR006	5.98	250	3625	300	3500	20.6	15.2
1DR009	9.00	250	3625	300	3500	31.7	23.4
1DR012	12.01	250	3625	300	3500	43.3	31.9
1DR015	15.02	250	3625	300	3500	54.4	40.1
1DR017	17.02	230	3335	300	3500	56.9	42.0
1DR019	19.03	210	3045	300	3500	58.5	43.2
1DR022	22.02	180	2610	300	3500	58.6	43.2
1DR027	27.03	145	2105	300	3500	58.8	43.4

OPERATING ENVELOPE-CONTINUOUS DUTY

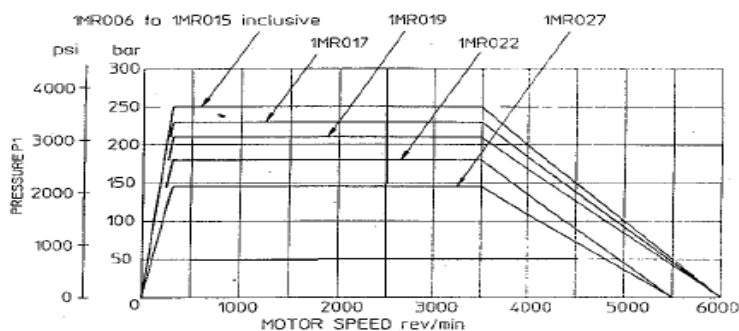

TYPICAL MOTOR INPUT FLOW

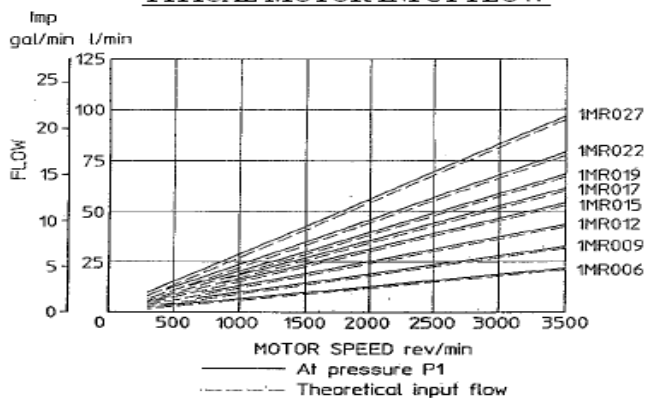

TYPICAL TORQUE CURVES AT PRESSURE P1

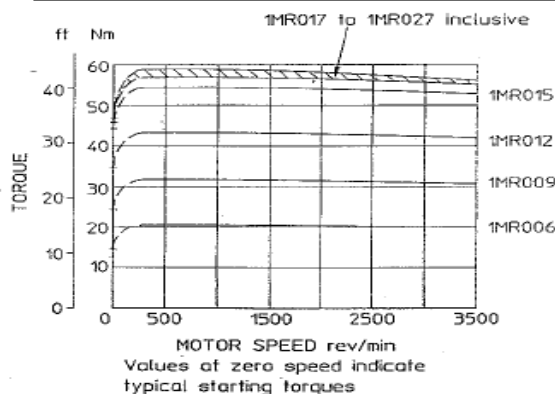

MOTOR DATA

MOTOR BASIC DIMENSIONS

Motor shown :- code 1DR019 TDTXN, ref only

Geometric tolerance symbols to BS 308

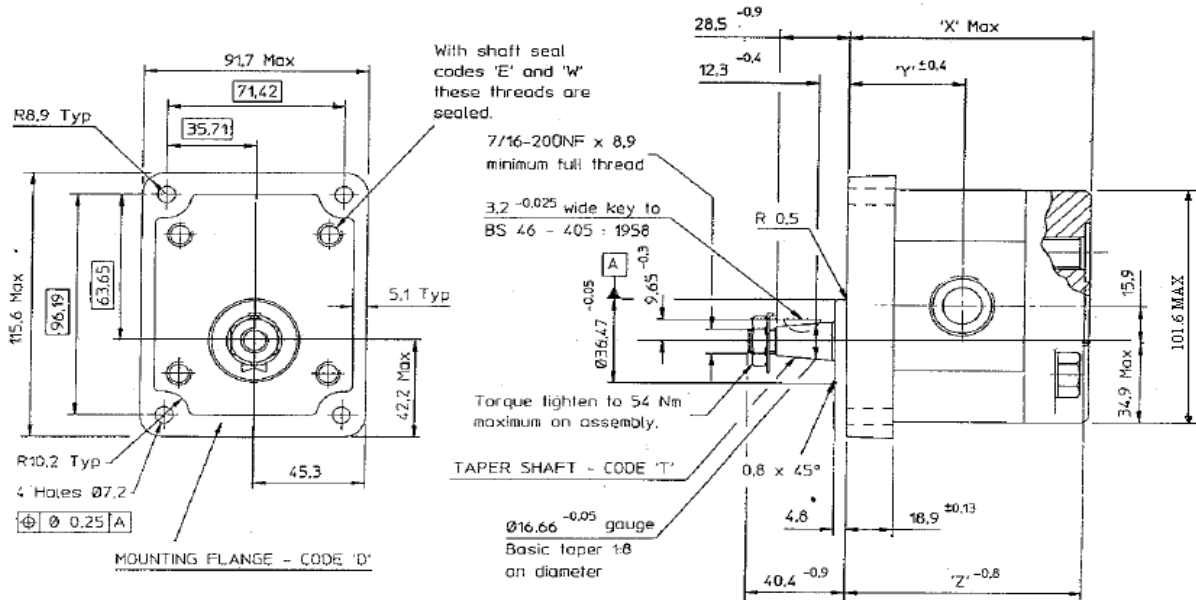

Metric body ports - Code 'E'

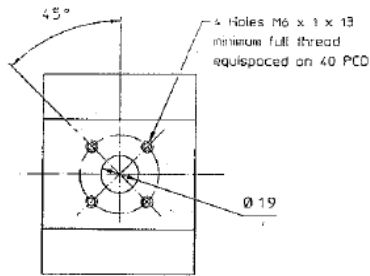

Ports are identical both sides

SAE 'O' Ring body ports- Code 'J'

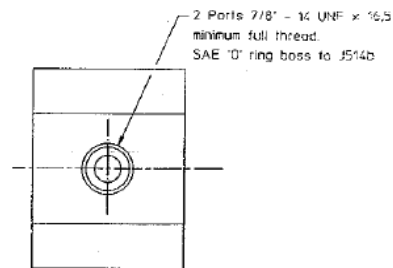

Ports are identical both sides

Body ports-Code 'F'

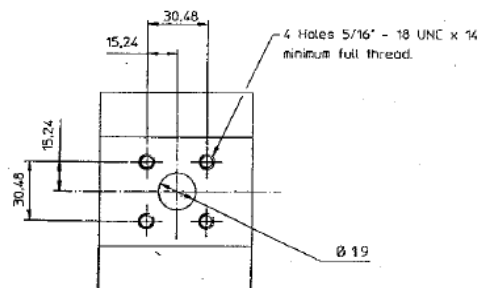

BSPF Body ports -Code 'T'

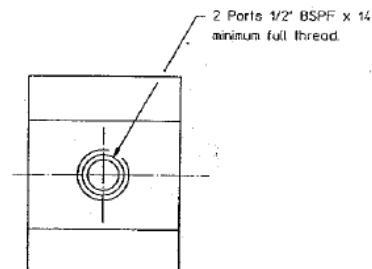

All dimensions are in mm unless otherwise specified



MOTOR DATA

FLOW SIZE	DIMENSIONS	DIMENSIONS 'X'	DIMENSIONS 'Z'	APPROX. WEIGHT 'Kg'
	'Y'			
006	44.1	96.1	94.8	2.3
009	46.4	100.9	99.6	2.4
012	48.8	105.6	104.3	2.5
015	51.1	110.3	109.0	2.7
017	52.7	113.5	112.2	2.8
019	54.2	116.6	115.3	2.9
022	56.6	121.3	120.0	3.0
027	60.6	129.2	127.9	3.2

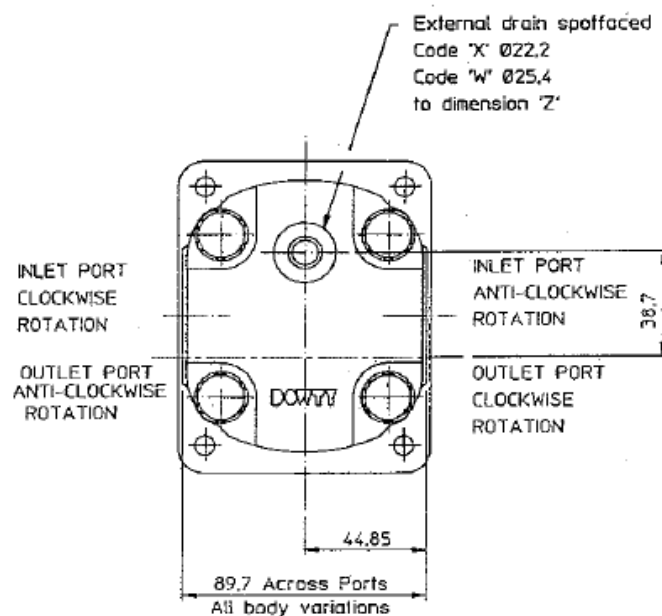

END COVER				
COVER CODE	PORTS	MIN FULL THREAD	DRAIN	MIN FULL THREAD
W	NONE	N/A	9/16-18 UNF	14
X	NONE	N/A	¼ BSPF	12.7
Y	NONE	N/A	INTERNAL	N/A
Z	NONE	N/A	NONE	N/A
Q	7/8-14 UNF	16.5	9/16-18 UNF	14.0
R	½ BSPF	15.2	1/4BSPF	12.7
S	7/8-14 UNF	16.5	INTERNAL	N/A
T	½ BSPF	15.2	INTERNAL	N/A
U	7/8-14 UNF	16.5	N/A	N/A
V	½ BSPF	15.2	N/A	N/A

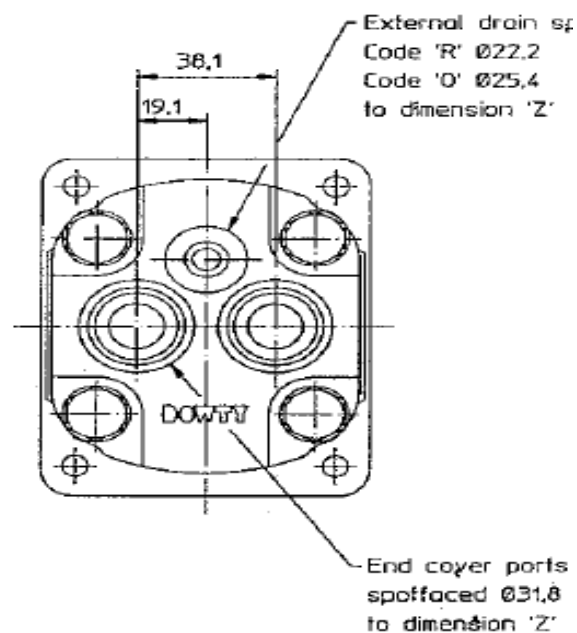

MOTOR DATA

MOUNTING FLANGE - CODE 'S' - SAE 'A' 2 BOLT

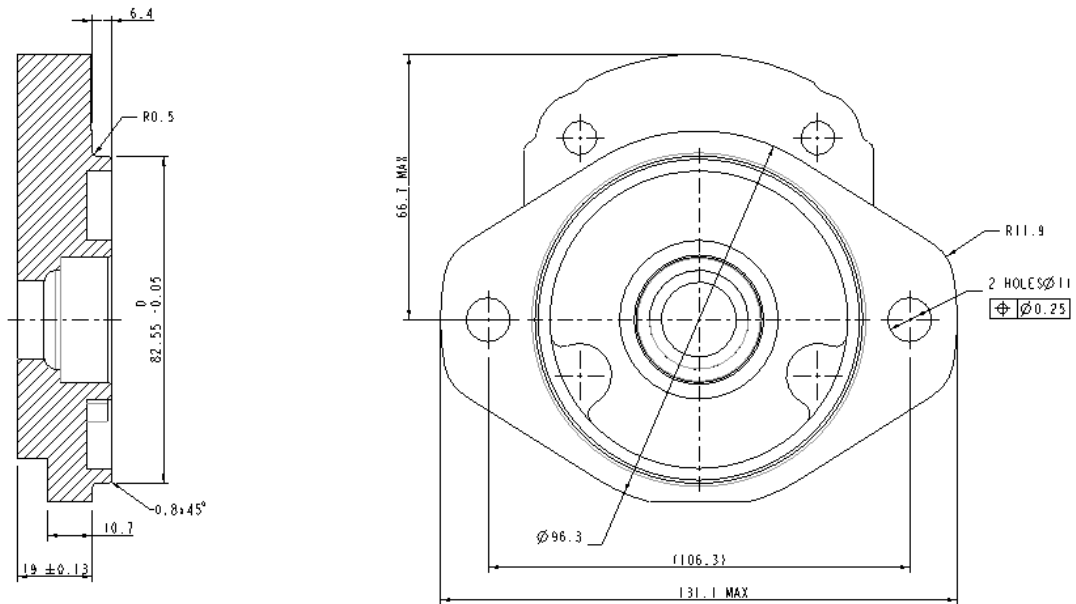

SPLINED SHAFT - CODE 'S'

SAE Spline, flat root,
side fit, 9 teeth, 16/32 DP.
Circular tooth thickness 0,13
less than SAE J498a class 1 std.

Undercut $\varnothing 11,94^{-0,25}$
with 1,3 max corner radii

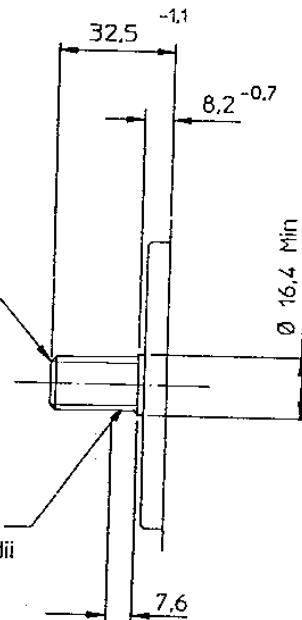

All dimensions are in mm unless otherwise specified

MOTOR DATA

PARALLEL SHAFT- CODE 'L'-SAE 'A'

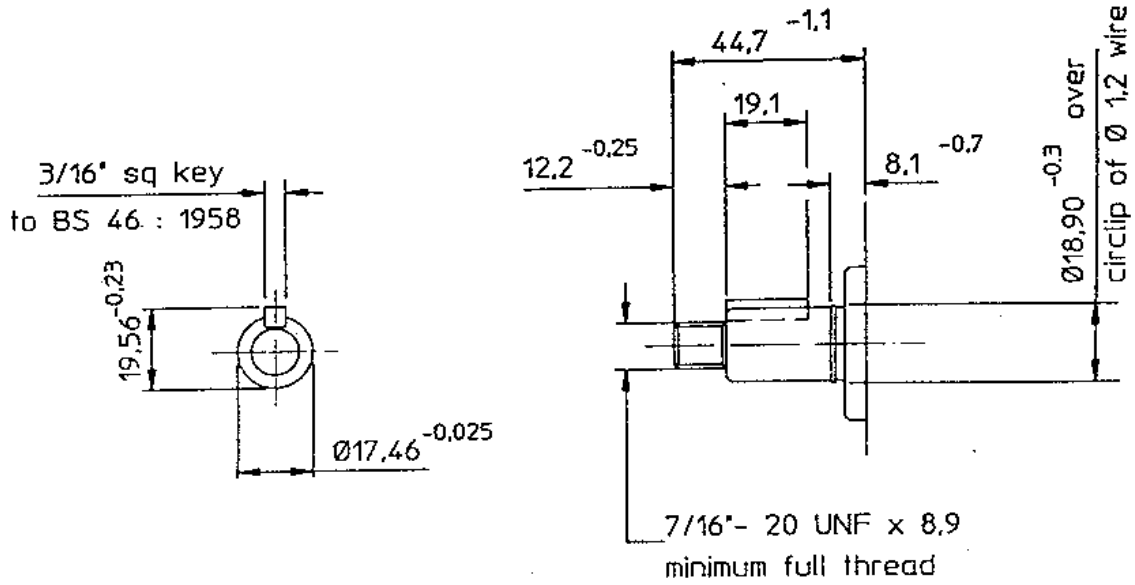

PARALLEL SHAFT-CODE 'L'-SAE 'A'

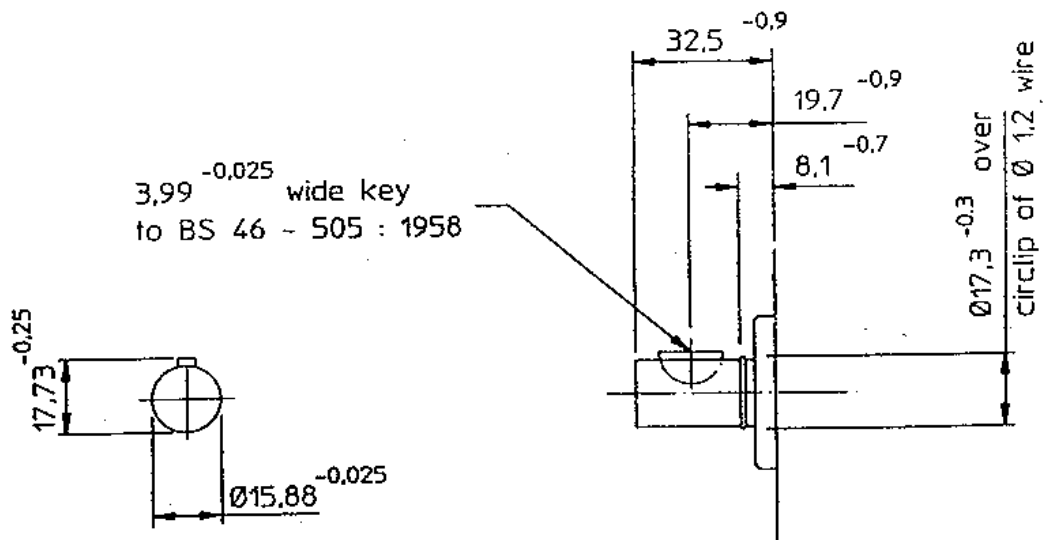

All dimensions are in mm unless otherwise specified



MOTOR DATA

PORTS

Dynamatic motors can be supplied with side or end cover ports and reversible motors need a separate drain line, although where pressure levels do not exceed the pressure rating of the shaft seal, integral chuck valves can be specified . see coding chart for full details.

OPERATING TEMPERATURE

The table below gives permissible operating temperature ranges to various shaft seal types

SHAFT SEAL CODES	OPERATING TEMPERATURE	
	CONTINUOUS	INTERMITTENT
E,M & N	0 ⁰ C to 80 ⁰ C	-20 ⁰ C to 100 ⁰ C
V & W	0 ⁰ C to 100 ⁰ C	-20 ⁰ C to 120 ⁰ C

MOTOR RETURN LINE

Back pressure in motor return lines must not exceed the rating of the shaft seal. For full detail of availability of shaft seal options and pressure rating see coding chart.

SERIES OPTION

Motors can be connected in series in which case the separate end port drain line must be used.

EXTERNAL DRAIN

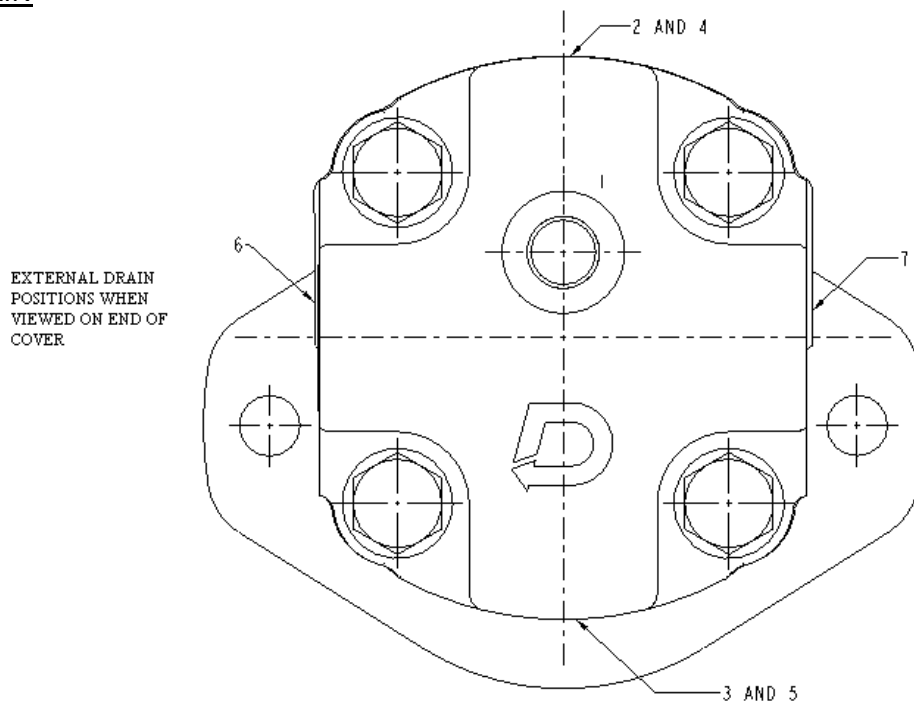

CODE	TYPE DESCRIPTION
A	¼"-18 NPTF
B	INTERNAL DRAIN
C	¼" BSPF
D	7/16"-20 UN SAE 'O' RING
E	9/16"-18 UN SAE 'O' RING
F	¼" BSPF 'O' RING
G	M12x1.5 'O' RING

CODE	POSITION DESCRIPTION
1	END FACE TOP OR INTN DRAIN
2	SIDE FACE TOP
3	SIDE FACE BOTTOM
4	SIDE FACE TOP 2 JOURNALS
5	SIDE FACE BOTTOM 2 JOURNALS
6	SIDE FACE LEFT HAND SIDE
7	SIDE FACE RIGHT HAND SIDE

EXTERNAL DRAIN POSITION WHEN VIEWED ON END OF COVER



CODING CHART

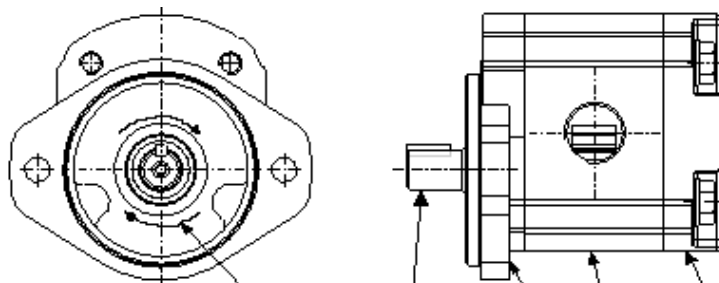

	FRAME SIZE	FLOW SIZE	ROTAATION	SHAFT	FLANGE	BODY	COVER	SHAFT SEAL
MOTORS	1DR							

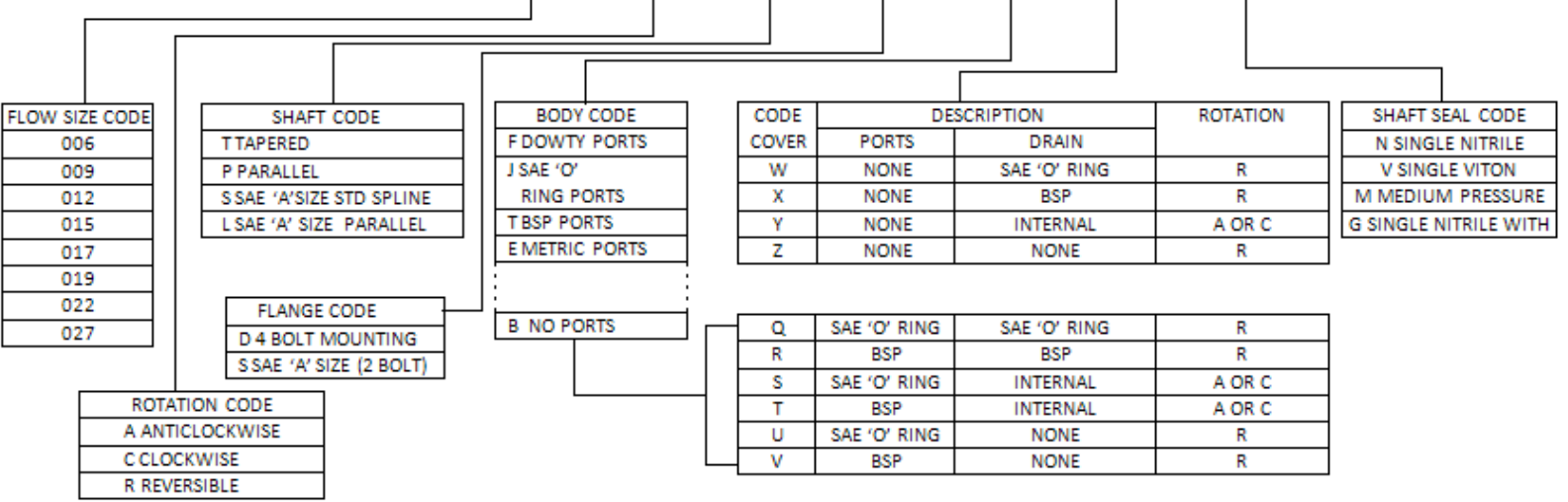

FLOW SIZE CODE
006
009
012
015
017
019
022
027

SHAFT CODE
T TAPERED
P PARALLEL
S SAE 'A' SIZE STD SPLINE
L SAE 'A' SIZE PARALLEL

FLANGE CODE
D 4 BOLT MOUNTING
S SAE 'A' SIZE (2 BOLT)

ROTATION CODE
A ANTICLOCKWISE
C CLOCKWISE
R REVERSIBLE

BODY CODE
F DOWTY PORTS
J SAE 'O' RING PORTS
T BSP PORTS
E METRIC PORTS
...
B NO PORTS

CODE COVER	DESCRIPTION		ROTATION
	PORTS	DRAIN	
W	NONE	SAE 'O' RING	R
X	NONE	BSP	R
Y	NONE	INTERNAL	A OR C
Z	NONE	NONE	R

SHAFT SEAL CODE
N SINGLE NITRILE
V SINGLE VITON
M MEDIUM PRESSURE
G SINGLE NITRILE WITH

CODE COVER	SAE 'O' RING	SAE 'O' RING	ROTATION
Q	SAE 'O' RING	SAE 'O' RING	R
R	BSP	BSP	R
S	SAE 'O' RING	INTERNAL	A OR C
T	BSP	INTERNAL	A OR C
U	SAE 'O' RING	NONE	R
V	BSP	NONE	R

EXAMPLE OF ORDERING CODE

EXAMPLE OF ORDERING CODE:-

FRAME SIZE	FLOW SIZE	ROTATION	SHAFT	FLANGE	BODY	COVER	SHAFT SEAL
1DR	022	R	S	D	T	Z	M

This order code specifies a 1DR022 gear motor of $-22.02\text{cm}^3/\text{rev}$ capacity.

Reversible rotation

S.A.E 'A' size splined shaft

'D' Flange

BSP ported body

Non Ported end cover, without Drain.

Medium Pressure shaft seal,

SHAFT SEAL DATA							
SHAFT SEAL CODE	PUMP				MOTOR		
	N	V	E	W	N	M	
MAXIMUM PRESSURE AT SHAFT SEAL							
CONTINEOUS	1 bar				5	10	
INTERMITTENT	1.5 bar				10	17	
TEMPERATURE RANGE °C							
NORMAL	MINIMUM	0	0	0	0	0	
	MAXIMUM	80	100	80	100	100	
INTERMITTENT	MINIMUM	-20	-20	-20	-20	-20	
	MAXIMUM	100	120	100	120	100	